

U.S. Department of Transportation

United States Coast Guard

**SAFETY
STANDARDS
FOR
BACKYARD
BOAT BUILDERS**

This pamphlet was created in the 80's. Since then the outboard motor weight information in table 4 has been revised several times and motor weights have changed significantly. But the formulas are still the same. (03/13/2024)

COMDTPUB P16761.3B

U.S. Department
Of Transportation

Commandant
United States Coast Guard

Washington, DC 20593-0001
Staff Symbol: (G-NAB-6)
Phone (2021) 267-0981

**United States
Coast Guard**

FOREWORD

This pamphlet, "SAFETY STANDARDS FOR BACKYARD BOAT BUILDERS," (COMDTPUB P16761.3B), is a simplified explanation of Federal recreational boat construction requirements and is intended for the use of the non-professional, individual builder. The primary objective of these requirements is to avoid certain safety hazards which have been found to be the cause of boating accidents.

This pamphlet is routinely sent to new manufacturers of recreational boats for the purposes of sale, because it gives a good explanation of how to go about complying with certain portions of the Federal safety standards and regulations. However, boat manufacturers are reminded that this pamphlet should not be used as a substitute reference for the applicable portions of the Code of Federal Regulations with which they are ultimately responsible for compliance.

The standards and regulations explained in this pamphlet were issued under the provisions of Chapter II of Title 46 of the United States Code and appear in Subchapter S (Boating Safety) of Chapter 1, Title 33 (Coast Guard, Department of Transportation) of the Code of Federal Regulations.

The previous edition of this pamphlet, COMDTPUB P16761.3A, dated August 24, 1988 is cancelled.

W. J. Ecker
Rear Admiral, U.S. Coast Guard
Chief, Office of Navigation Safety
and Waterway Services

CONTENTS

SAFE POWERING	2
SAFE LOADING	6
BASIC FLOTATION	16
LEVEL FLOTATION	16
LOCATION OF FLOTATION MATERIAL	26
LEVEL FLOTATION RETROFIT	29
VENTILATION	30
GASOLINE FUEL SYSTEMS	34
ELECTRICAL SYSTEMS	35
CAPACITY LABEL	36
HULL IDENTIFICATION NUMBER	37
CERTIFICATION LABEL	38
FLOTATION MATERIALS	39
SURVIVAL HANDLES	43
STATE ISSUING AUTHORITIES	46
COAST GUARD DISTRICTS	50

NOTE

READ THIS ENTIRE PAMPHLET BEFORE YOU BEGIN ANY OF THE CALCULATIONS IN A PARTICULAR SECTION.

Boating accidents cause property damage, often result in injuries and may even result in deaths. The best way to avoid a serious boating accident is to know safe boating practices, use sound judgement while boating and build safety features into your boat. This will not only reduce your chances of ever having a boating accident, but also give you a better chance of surviving if you do have one.

The Coast Guard has published this pamphlet to explain Coast Guard required safety standards to people who intend to build their own boats.

The Coast Guard safety standards and the boats to which they apply are outlined below:

	Less than 20 feet in length			Greater than or Equal to 20 feet in length	
	Rowboats	O/B	I/B & I/O	O/B	I/B & O/B
SAFE LOADING	X	X	X		
SAFE POWERING		X			
FLOTATION	X	X	X		
FUEL (GAS)			X		X
ELECTRICAL (GAS)			X		X
VENTILATION		X*	X	X*	X
CAPACITY LABEL	X	X	X		
CERTIFICATION LABEL	X	X	X	X*	X
HIN ALL BOATS MUST BEAR TWO HULL IDENTIFICATION NUMBERS					

NOTE

SAILBOATS WITH GASOLINE POWERED INBOARD AUXILIARY ENGINES AND ALL BOATS WITH PERMANENTLY INSTALLED GASOLINE GENERATORS MUST MEET THE REQUIREMENTS FOR FUEL SYSTEMS, ELECTRICAL SYSTEMS, VENTILATION SYSTEMS AND A CERTIFICATION LABEL.

ANY BOAT WITH A COMPARTMENT CONTAINING A GASOLINE FUEL TANK MUST MEET THE REQUIREMENTS FOR VENTILATION.

SAILBOATS (EXCEPT INBOARD AUXILIARIES), CANOES, KAYAKS, INFLATABLES, SUBMERSIBLES, RACEBOATS, SURFACE EFFECT VESSELS AND AMPHIBIOUS VEHICLES ARE EXCEPTED FROM ALL REQUIREMENTS EXCEPT FOR THE HULL IDENTIFICATION NUMBERS.

This pamphlet shows how to calculate your boat's safe horsepower capacity (if it will be powered by an outboard) and its safe load capacity (both in pounds and the numbers of people). This pamphlet also explains how to determine how much flotation material you need to keep your boat afloat if it is swamped, and where to install the flotation. Also, if your boat will carry a gasoline powered inboard or inboard/outdrive engine, we'll explain the Electrical System, Fuel System and Ventilation System regulations and tell you how to get additional information which describes the requirements in greater detail. Also included in Appendix D is a design guideline for installing survival handles which are recommended for boats equipped with basic flotation.

To help you through the calculations covering Safe Powering and Safe Loading presented in this pamphlet, we have included on page 11 completely worked out examples for a 16.33 foot outboard runabout equipped with remote steering and a 9.58 foot dinghy with manual steering. Those of you who are building inboards and inboard/outdrives will have steps in addition to and different from those given in the example, but they should give you no trouble.

SAFE POWERING

HOW MUCH HORSEPOWER CAN YOU SAFELY PLACE ON YOUR OUTBOARD POWERED BOAT? (There is no limitation on the horsepower of inboards and inboard-outdrives.)

First measure the length of your boat and the width of its transom. Then you multiply these numbers to get a third number, called a factor. You then use this factor to find your safe horsepower capacity.

Keep your measurements in feet and hundredths of a foot. Here are some inches and their approximate hundredths to help you:

Inches	=	Hundredths
1	=	0.08
2	=	0.16
3	=	0.25
4	=	0.33
5	=	0.41
6	=	0.50
7	=	0.58
8	=	0.66
9	=	0.75
10	=	0.83
11	=	0.91
12	=	1.00

So for a boat 19 feet, 7 inches long, your measurement would read 19.58 feet.

BOAT LENGTH

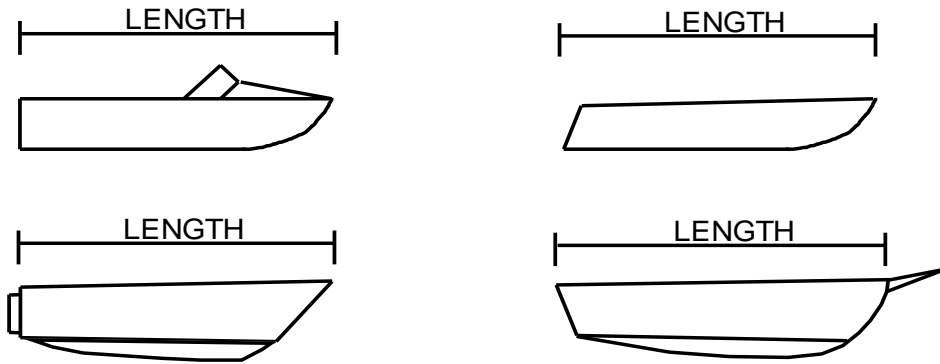

TRANSOM WIDTH

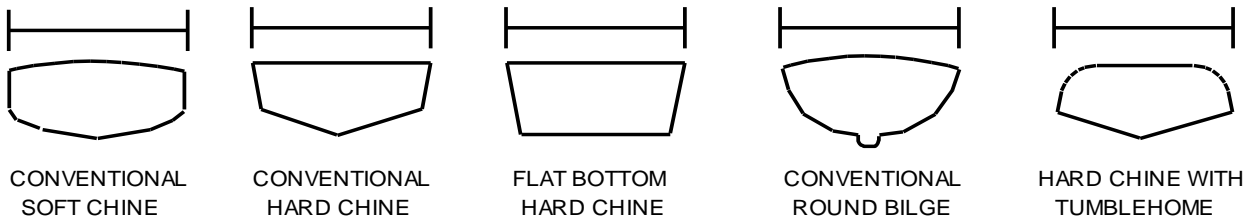

Spray rails can be included in your measurement of transom width if the rails act as part of the planing surface.

1. Measure boat length:

Boat length in feet is

2. Measure width of transom:

Transom width in feet is

3. Now multiply length times width to get your factor (that is, your answer).

4. Round off your factor to the nearest whole number. For .5 or above round off to the next higher whole number.

Factor is

FOR FACTORS BETWEEN 0 AND 52

If your factor number is between 0 and 52, your safe outboard horsepower capacity is as shown below:

Factor is:	Horsepower is:
0 – 35	3
36 – 39	5
40 – 42	7.5
43 – 45	10
46 – 52	15

BUT –

If your boat is flat-bottomed and has a hard chine, your horsepower is less than that indicated by your factor number. Your safe horsepower capacity will be the next lower horsepower rating.

For example, if your factor indicates you should use 5 HP, your SAFE capacity with a flat bottomed, hard chine boat is only 3 HP. Hard and soft chines are illustrated below.

Why? Because with a hard chine and a flat bottom you must turn more slowly to maintain stability.

FOR FACTORS ABOVE 52.0:

If your factor number is larger than 52.0, your safe outboard horsepower capacity is figured according to the type of steering you have and the height of your boat's transom.

TRANSOM HEIGHT

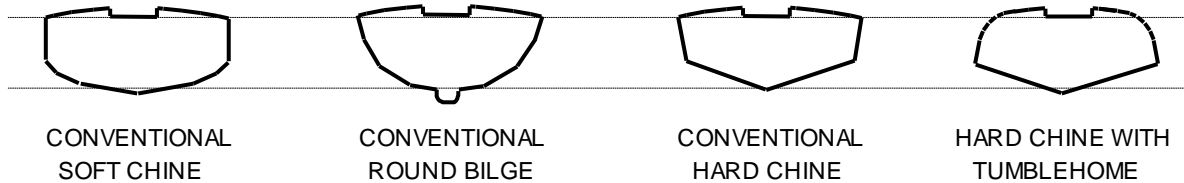

1. First measure transom height:

Transom height is _____ inches (This is usually either 15" or 20".)

FOR OUTBOARDS WITH REMOTE STEERING AND A TRANSOM HEIGHT OF AT LEAST 20 INCHES:

1. Multiply your factor by 2

$$\begin{array}{r} \text{_____} \\ \times \quad 2 \\ \hline \end{array}$$

2. Subtract 90

$$\begin{array}{r} \text{_____} \\ - \quad 90 \\ \hline \end{array}$$

3. Raise answer to nearest multiple of 5

HOW TO RAISE ANSWER TO NEAREST MULTIPLE OF 5

If the second numeral in your answer is a 5 or a 0, DO NOT CHANGE YOUR ANSWER.

If the second numeral in your answer is 1, 2, 3 or 4, change it to 5. For example, 21, 22, 23 or 24 would all be changed to 25.

If the second numeral in your answer is 6, 7, 8 or 9, change it to a 0 and raise the first numeral by 1. For example, 26, 27, 28 or 29 would all be changed to 30.

Maximum safe horsepower in calm water is _____

FOR OUTBOARDS THAT DO NOT HAVE REMOTE STEERING OR TRANSOM HEIGHT IS LESS THAN 20 INCHES (i.e. 19 inches) ---

1. Multiply factor by 0.8

$$\begin{array}{r} \text{_____} \\ \times \quad 8 \\ \hline \end{array}$$

2. Subtract 25

$$\begin{array}{r} \text{_____} \\ - \quad 25 \\ \hline \end{array}$$

3. Raise answer to nearest multiple of 5

$$\text{_____}$$

Maximum safe horsepower is _____

FOR FLAT-BOTTOMED, HARD-CHINE OUTBOARDS THAT DO NOT HAVE REMOTE STEERING OR TRANSOM HEIGHT IS LESS THAN 20 INCHES (i.e. 19 inches) - -

1. Multiply your factor by 0.5

_____ X 0.5

2. Subtract 15

_____ - 15

3. Raise answer to nearest multiple of 5
(See box previous page)

Maximum safe horsepower is _____

SAFE LOADING

Drownings are one of the most frequent causes of fatalities in recreational boating. Too often they are caused by people who try to carry more passengers and gear than their boat can safely carry. The Safe Loading regulations were developed to give boat operators a guide to their boats' safe loading capacities.

The Safe Loading regulations address two different load capacities of your boat, its maximum persons capacity (expressed in both the number of pounds and the number of persons) and its maximum weight capacity. These load capacities must be calculated separately because the maximum persons capacity is a live load, whereas, the maximum weight capacity includes your live load and fixed loads. The live load capacity is the weight which moves about your boat affecting its stability. Your boat's maximum weight capacity includes the live load capacity (people), the weight of the motor (if your boat is outboard powered), and the weight of the portable gear you can safely carry in calm water.

WEIGHING IN: To find out how much total portable weight your boat can safely carry you need to know two weights:

1. Test weight
2. Machinery weight (for inboards)

First we'll tell you how to get these numbers and then how to use them to figure your safe load in calm water.

NOTE: BEFORE INSTALLING YOUR INBOARD ENGINE READ THE SECTION BELOW ON GETTING YOUR TEST WEIGHT.

TEST WEIGHT. Your boat's test weight is the weight of the volume of water it takes to sink your boat. This is OK for a runabout or an outboard, but what about water damage to an installed inboard engine? To electrical wiring? To controls?

So if you are building an inboard, plan to get your test weight before you install your machinery, approximate the weight of your machinery, place that much weight in your boat, and then fill it with water. If you have already installed your engine and controls, find some way to protect them.

Your test weight is used to figure your maximum safe load. Your safe load, persons capacity, safe horsepower and flotation requirements are all used to help you understand your boat's maximum safe capacities.

Now, about filling your boat with water! First, float your boat in shallow water (easier to recover if it sinks), and second, start filling it with water from, say, a 5-gallon bucket. Keep the boat level and fill it until it is as low in the water as possible without sinking. **AND DON'T FILL YOUR BOAT ON DRY LAND, OR YOU'LL PROBABLY BURST OUT THE SIDES. WATER IS HEAVY. ONE GALLON WEIGHS ABOUT EIGHT POUNDS.** Flotation material should not be in the boat during this test.

When the boat is full and level, you will have the number of buckets it took to fill it. Multiply this number by the size of your bucket - - 2, 3, 5 or whatever number of gallons it holds. This gives you the number of gallons of water in your boat. Now multiply the number of gallons by 8, because 1 gallon of water equals approximately 8 pounds. Your answer approximates the weight of the water it takes to sink your boat.

Test weight is _____

MACHINERY WEIGHT (inboards only). Your machinery weight is the weight of your installed engine, full fuel tanks, controls, drive units and batteries. You should be able to get the weight of the motor, fuel tanks and drive units from the manufacturers. One gallon of gasoline weighs about 6 pounds. So you multiply the number of gallons your fuel tanks will hold by 6 to get the weight of your tanks when they are full of fuel. The typical 12 volt battery weighs 25 pounds.

YOUR SAFE LOAD. So far you've gone to a great deal of trouble to get these two weights - - test weight and machinery weight. What do they mean? And how are they used to keep you from capsizing because of an overloaded boat?

The big question is: How much total weight can you bring aboard your boat without it being a hazard? Remember, we are considering only calm water. If there is a wind, your weight should be reduced, of course. So, here's how to figure your safe load.

FOR BOATS RATED FOR MANUAL PROPULSION AND BOATS RATED FOR OUTBOARD MOTORS, TWO HORSEPOWER OR LESS.

1. Calculate three-tenths of your boat's test weight.

$$\underline{\hspace{2cm}} \times 0.3$$

Your maximum safe load in calm water is

$$\underline{\hspace{2cm}}$$

FOR BOATS RATED FOR OUTBOARD MOTORS LARGER THAN TWO HORSEPOWER

1. Divide Test weight by 5

$$5 / \underline{\hspace{2cm}}$$

Your maximum safe load in calm water is:

$$\underline{\hspace{2cm}}$$

FOR INBOARDS AND INBOARD-OUTDRIVES

1. Divide your test weight by 7

$$7 / \underline{\hspace{2cm}}$$

Your maximum safe load for your inboard is:

$$\underline{\hspace{2cm}}$$

NOTE: EMPTY WATER FROM BOAT BEFORE CONDUCTING NEXT TEST

HOW MANY PEOPLE? You have just figured out what your maximum safe load is - - but how many people weighing how many pounds can you safely carry? Often your "live load capacity" will be less than the maximum safe load you just figured. Your boat's maximum persons capacity in pounds will depend upon the size of the maximum weight capacity you calculated for your boat.

FOR BOATS RATED FOR MANUAL PROPULSION (PADDLED OR OARS)

1. The maximum persons capacity in pounds is 90% of the maximum weight capacity you calculated on page 8.

$$\begin{array}{r} \text{_____} \\ \times \quad .9 \\ \hline \end{array}$$

Your maximum persons capacity is _____

FOR BOATS RATED FOR OUTBOARD MOTORS TWO HORSEPOWER OR LESS:

1. The maximum persons capacity in pounds is 90% of the maximum weight capacity you calculated on page 8 minus 25 pounds (the weight of the motor).

$$\begin{array}{r} \text{_____} \\ \times \quad .9 \\ \hline \\ \text{_____} \\ - \quad 25 \\ \hline \end{array}$$

Your maximum persons capacity is _____

FOR BOATS RATED FOR OUTBOARD MOTORS MORE THAN 2 HORSEPOWER:

1. Subtract the motor and control weight, battery weight, and full portable fuel tank weight (see Column 6 of Table 1 in Appendix C) from the maximum weight capacity you calculated on page 8.

$$\begin{array}{r} \text{_____} \\ \text{_____} \\ \text{_____} \\ \hline \end{array}$$

2. If your answer is more than 550 pounds, it is your maximum persons capacity and you do not have to conduct the Stability Test.

3. If your answer is 550 pounds or less, perform the Stability Test described on the next page. Your maximum persons capacity is whichever of the two numbers is lowest.

FOR INBOARD AND INBOARD-OUTDRIVE BOATS:

1. If the maximum weight capacity from page 8 is larger than 550 pounds, the maximum persons capacity in pounds must not exceed the maximum weight capacity.
2. If the maximum weight capacity from page 8 is 550 pounds or less, perform the following Stability Test:

STABILITY TEST FOR MAXIMUM PERSONS CAPACITY: To perform the Stability Test you add weights along one side of your boat's cockpit area at seat height until the boat rolls to a position just before water starts to come aboard.

To make this as easy as possible, float your boat in shallow water near a dock, and on the dock have a bathroom scale. If your boat is an outboard, attach the motor with a full fuel tank; if it is an inboard, have all your normal equipment aboard, including full fuel tanks.

First put a board along one side of the cockpit area at seat height (be sure to weigh the board). Now start weighing objects or people and, starting from the center of the board, add weights as evenly fore and aft of center as possible, as far outboard as possible, and at seat height.

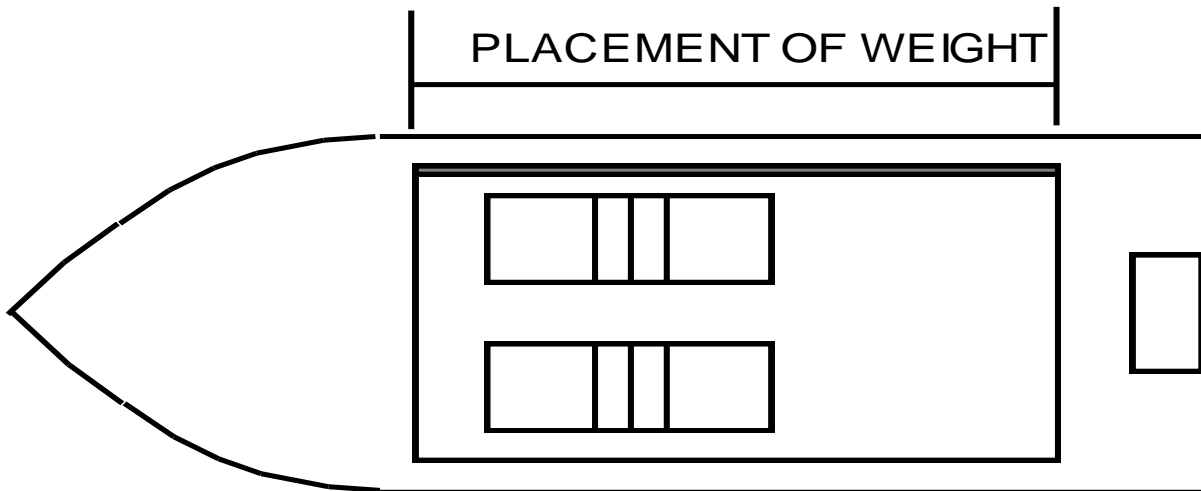

Use anything you want for weight – people, bricks, buckets of rocks, bags of sand – but keep track of the weight of each object added. When the boat is tilted to the point just before water starts to come aboard, stop adding weight.

Be very careful at this point. Your boat could very easily tip a bit and take on water, which you don't want. Add up the total number of pounds of weight you placed on the board (including the weight of the board.)

Pounds added are: _____

Now you need to divide this number by 0.6. Again, let's do it the easy way. First, multiply your number of pounds by ten: Just add a zero (0) to it. Now divide by six. This way you get rid of the decimal point.

Here is an example:

Say you added 600 pounds to one side of your boat, 300 pounds forward and 300 pounds aft of center.

1. Add a zero to 600 making it 6000
2. And divide by 6

$$\frac{6000}{6} = 1000 \text{ pounds}$$

NOTE

IF YOUR ANSWER AFTER PERFORMING THE STABILITY TEST IS LARGER THAN THE MAXIMUM WEIGHT CAPACITY YOU CALCULATED:

FOR INBOARDS, YOUR MAXIMUM PERSONS CAPACITY IS THE SAME AS YOUR MAXIMUM WEIGHT CAPACITY.

FOR OUTBOARDS, YOUR MAXIMUM PERSONS CAPACITY IS THE MAXIMUM WEIGHT CAPACITY MINUS THE WEIGHT IN COLUMN 6 OF TABLE 1 FOR YOUR OUTBOARD MOTOR.

Now let's convert your maximum persons capacity to the numbers of people.

COMPUTING PERSONS CAPACITY IN NUMBER OF PEOPLE

1. Add 32 pounds to your maximum persons capacity.
2. Divide the sum by 141.
3. Round off the result to the nearest whole number.

$$\begin{array}{r} \text{_____} \text{ persons capacity} \\ + \quad 32 \\ \hline \text{_____} \\ 141 / \end{array}$$

If your fraction is less than one-half, or 3.43 for example, round down to 3 people.

If your fraction is .5 or higher, or 3.52 for example, round up to 4 people.

Your boat can safely carry a maximum of _____people.

You now have a maximum safe load (maximum weight capacity) and a maximum persons capacity in pounds and total number of persons.

NEVER TAKE ON MORE TOTAL WEIGHT THAN THE MAXIMUM WEIGHT CAPACITY OR MORE PEOPLE THAN THE MAXIMUM PERSONS CAPACITY.

On page 36 we'll show you where this information and your maximum horsepower capacity must be displayed.

EXAMPLES COVERING SAFE LOADING AND SAFE POWERING

EXAMPLE A

Boat is deep-V type

Assume Length is: 16 ft., 4 in. (16.33 feet)

Assume Width of transom is: 5 ft., 2 in. (5.17 feet)

Assume Height of transom is: 19 inches

MAXIMUM SAFE HORSEPOWER

(outboards only)

Boat length is: 16.33 feet

Transom width is: 5.17 feet

Multiply length and width to get factor:

$$\begin{array}{r} 16.33 \\ \times 5.17 \\ \hline 11431 \\ 1633 \\ 8165 \\ \hline 84.4261 \end{array}$$

Factor is 84

When factor (84) is above 52.0, type of steering is remote, and transom height is at least 19 inches.

Multiply factor by 2: $84 \times 2 = 168$ Subtract 90 $168 - 90 = 78$

Raise answer to nearest multiple of 5: 80

Maximum Safe Horsepower is 80 HP

MAXIMUM SAFE LOAD

Assume Test Weight is 6,000 pounds.

NOTE: THE TEST WEIGHT GIVEN ABOVE IS EQUIVALENT TO APPROXIMATELY 150 5-GALLON BUCKETS OF WATER.

Divide test weight by 5

$$\frac{1200}{5 / 6000}$$

Maximum Safe Load is 1200 pounds

PERSONS CAPACITY

The maximum weight capacity is larger than 550 pounds. The maximum persons capacity in pounds must not exceed the maximum weight capacity minus the motor and control weight, battery weight and full portable fuel tank weight (see Column 6 of Table 1 in Appendix C).

80 horsepower motor (Column 6, Table 1) = 425 pounds

$$\begin{array}{r} 1200 \\ - 425 \\ \hline 775 \end{array}$$

Maximum Persons Capacity is 775 pounds.

PERSONS CAPACITY IN NUMBER OF PEOPLE

Persons Capacity is	775 pounds
Add 32	<u>+ 32</u>
	807

Divide sum by 141 $\frac{807}{141} = 5.7$

Fraction is more than .5, so round up to 6

Maximum Persons Capacity is 6 people.

EXAMPLE B

Boat is soft chine dinghy

Assume Length is: 9 ft., 7 in. (9.58 feet)

Assume Width of transom is: 4 ft., 9 in. (4.75 feet)

Assume Height of transom is: 15 inches

MAXIMUM SAFE HORSEPOWER (outboards only)

Boat length 9.58 feet
Transom width 4.75 feet

Multiply length and width to get factor

$$\begin{array}{r} 9.58 \\ \times 4.75 \\ \hline 4790 \\ 6706 \\ 3832 \\ \hline 45.5050 \end{array}$$

Factor is 46 (for .5 or above round to next higher whole number)

Type of steering: Manual (tiller or motor)
Height of transom: 15 inches

For factor 46 to 52 horsepower capacity is 15 (see page 4).

Maximum safe Horsepower is 15 HP.

MAXIMUM SAFE LOAD

Assume Test Weight is 2,650 pounds

NOTE: THE TEST WEIGHT GIVEN ABOVE IS EQUIVALENT TO APPROXIMATELY 66 5-GALLON BUCKETS OF WATER.

Divide test weight by 5

$$\begin{array}{r} 530 \\ \hline 5 / 2650 \end{array}$$

Maximum Safe Load is 530 pounds.

PERSONS CAPACITY

Subtract the value in Column 6 of Table 1 for Maximum Horsepower Capacity from the Maximum Weight Capacity.

15 horsepower motor (Column 6, Table 1) = 160 pounds

$$\begin{array}{r} 530 \\ - 160 \\ \hline 370 \end{array}$$

Since the answer is 550 pounds or less, perform the Stability Test.

STABILITY TEST

Assume pounds added to one side of boat = 210 pounds

Divide by 0.6

$$\begin{array}{r} 350 \\ .6 / 210 \end{array}$$

OR

Multiply by 10 and divide by 6

$$10 \times 210 = 2100$$

$$\begin{array}{r} 350 \\ 6 / 2100 \end{array}$$

Maximum Persons Capacity is 350 pounds.

Since the 350 pounds calculated using the stability test is the lowest of the two values, the maximum persons capacity is 350 pounds.

PERSONS CAPACITY IN NUMBER OF PEOPLE

$$\begin{array}{r} \text{Persons Capacity} \quad 350 \\ \text{Add 32} \quad \quad \quad \quad \underline{+32} \\ \quad \quad \quad \quad \quad \quad 382 \end{array}$$

Divide sum by 141

$$\begin{array}{r} 2.70 \\ 141 / 382.00 \end{array}$$

Fraction is more than .5 so round up to 3

Maximum Persons Capacity is 3 people.

Now you know how many people, how much gear, and in the case of outboards how much horsepower your boat can safely carry. On page 36 we'll show you where to display this information. Overloading and overpowering cause many boating accidents, particularly capsizings, which is why these capacities are important to the safe operation of your boat.

But suppose your boat capsized for other reasons. A wave might break over your boat's transom or you might hit a submerged object. In both instances your boat could become filled with water, which would probably cause it to capsize. Then, if your boat sank beneath you, you'd have nothing to hang onto. The length of time you survived would probably be minimal.

FLOTATION

BASIC FLOTATION. Builders of inboards and inboard-outdrives are required to comply with the Basic Flotation portion of the Coast Guard Flotation Standard. Basic Flotation requires a fully loaded boat to float with some portion of the boat above the surface of the water when it is swamped. This means that the boat must contain sufficient flotation to support two-fifteenths (2/15) of the persons capacity and 25 percent of the dead weight. Basic Flotation is designed to give the survivors of a boating accident in which the boat has swamped something on the hull to hang onto. The advantages of Level Flotation versus Basic Flotation are obvious (see introductory paragraphs to Level Flotation section).

Builders of boats that are subject to the Basic Flotation requirements should perform Steps I and II in the "Calculations section on the following pages and substitute 25 percent of their boats' rated maximum weight capacity for Step III in the appropriate example. Also, since Basic Flotation requires only that some portion of the boat remain above the surface of the water, the location for the required amount of flotation material is unimportant.

NOTE:

BECAUSE OF THE INHERENT ADVANTAGES OF LEVEL FLOTATION, ALL BUILDERS ARE ENCOURAGED TO BUILD THEIR BOATS IN COMPLIANCE WITH THE LEVEL FLOTATION STANDARD DESCRIBED ON THE FOLLOWING PAGES. BUILDERS WHO CHOOSE BASIC FLOTATION IN LIEU OF THE ADDED SAFETY FEATURE PROVIDED BY LEVEL FLOTATION ARE URGED TO CONSIDER INSTALLING THE SURVIVAL HANDLES DESCRIBED IN APPENDIX D.

LEVEL FLOTATION. Level Flotation will increase both your ability to survive and the ability of rescue groups to locate you after an accident has occurred. Level Flotation does just what its name sounds like. If a boat fills with water, Level Flotation will make the boat float level. You and your passengers will actually be able to remain inside the

boat even though it is full of water. There you will be warmer, feel safer, be less in danger of drowning and will provide a larger target for rescue groups to locate. If the seas are calm, you might be able to bail the water out of your boat and if the powerhead of your motor wasn't damaged by immersion in the water, you might be able to return to shore under your own power.

The Level Flotation Standard applies to monohull outboard powered boats less than 20 feet in length except sailboats, canoes, kayaks, inflatables, submersibles, race boats, surface effect vessels and amphibious vehicles. The principles of Level Flotation, however, may be applied to many of these excepted boats at your option.

Level Flotation will not make your boat right itself if it overturns, but it reduces the probability that your boat will capsize. If it does capsize, one or two people should be able to right it. If you are unable to right the boat, you and your passengers can still get out of the water and sit on the bottom of the overturned boat.

In order to make your boat float level when full of water, enough flotation material must be installed in specific areas to:

1. Support the weight of your boat;
2. Support your weight and the weight of your passengers (your boat's maximum persons capacity); and
3. Support the weight of the motor and related equipment (if your boat is powered).

Each of these three quantities of flotation must be installed "symmetrically" and as close to the gunwales as possible. We'll tell you more about what we mean about symmetrically later, but first let's figure out how much flotation you'll need, then we'll show you how and where to install it.

CALCULATIONS

On the following pages are four examples of how to calculate how much flotation material is required in four different boats. Choose the example which most closely resembles your boat and substitute your own figures for boat weight, deck weight, maximum persons capacity, maximum weight capacity and maximum horsepower.

EXAMPLE	APPLIES TO
A	Boats rowed or paddled or 2 HP or less
B	Small outboard runabouts and jonboats
C	Larger outboard runabouts
D	Inboards and sterndrives

NOTE: IF YOUR BOAT ALREADY CONTAINS BASIC FLOTATION, DISREGARD STEPS I AND II IN YOUR EXAPMLE AND GO ON TO STEP III.

NOTE: ALL DECIMAL PLACES IN STEPS I, II AND III SHOULD BE ROUNDED UP TO THE NEXT HIGHER WHOLE NUMBER: 9.1 SHOULD BE ROUNDED UP TO 10 AND 7.7 TO 8.0. IN SOME CASES YOU MIGHT END UP WITH A NEGATIVE NUMBER. IF YOU DO, DO NOT ROUND IT UP.

EXAMPLE A - - 9-FOOT PLYWOOD DINGHY (Anyone building a boat that will be manually propelled (rowed or paddled) or powered by an outboard motor two horsepower or less should follow the calculations in this example).

Assume Hull Weight is: 75 lbs.
 Assume Deck Weight is: 0 lbs.
 Assume Maximum Persons Capacity is: 300 lbs.
 Assume Maximum Weight Capacity is: 400 lbs.
 Assume Maximum Horsepower is: 1.5 HP

NOTE: IF YOU ARE RETROFITTING A BOAT BUILT PRIOR TO 1978 THAT IS ALREADY EQUIPPED WITH BASIC FLOTATION, YOU MAY DISCOVER THAT THE MAXIMUM PERSONS CAPACITY IS INDICATED IN PERSONS INSTEAD OF POUNDS. TO CONVERT TO POUNDS, MULTIPLY THE NUMBER OF PERSONS BY 160 POUNDS.

STEP I
DETERMINE FLOTATION MATERIAL NEEDED TO SUPPORT SWAMPED BOAT (Fb).

Formula:
$$(Fb) = \frac{(Wh \times K) + Wd}{B}$$

Where:

Wh = Dry Weight of Hull = 75 lbs.
 Wd = Dry Weight of Deck = 0 lbs.
 (Wd normally would include everything above the gunwales including windshield, hardware and accessories.)
 K = Conversion Factor for Plywood = -.81
 (See Appendix B for other materials)
 B = Buoyancy of Flotation Material in pounds per cubic foot = 60.4
 (See page 39)

$$(Fb) = \frac{75 \times (-.81) + 0}{60.4}$$

$$(Fb) = \frac{-60.75}{60.4} = -1.0$$

Flotation to support the boat = - 1.0 cubic feet

(a negative number because plywood is buoyant)

**STEP II
DETERMINE FLOTATION MATERIAL NEEDED TO SUPPORT
SWAMPED MOTOR (Fm)**

(If your boat will not be powered disregard this step.)

Formula: $(Fm) = \frac{S}{B}$

Where:

S = Total Swamped Weight = 20 lbs.
(locate in Table 1 the boat's maximum horsepower)

B = Buoyancy of Flotation Material in pounds per cubic foot = 60.4
(See page 39)

$$(Fm) = \frac{20}{60.4} = .33 \text{ rounded up} = 1.0$$

Flotation to support the motor = 1.0 cubic foot

**STEP III
DETERMINE FLOTATION MATERIAL NEEDED TO SUPPORT
PERSONS CAPACITY (Fpc)**

Formula: $(Fpc) = \frac{.15(PC)}{B}$

Where:

PC = Maximum Persons Capacity in pounds = 300 lbs.
B = Buoyancy of Flotation Material in pounds per cubic foot = 60.4

$$(Fpc) = \frac{.15(300)}{60.4} = \frac{45}{60.4} = .74 \text{ rounded up} = 1.0$$

Flotation to support persons capacity = 1.0 cubic foot

**STEP IV
DETERMINE TOTAL FLOTATION MATERIAL NEEDED (Ft)**

Formula: $(Ft) = (Fb) + (Fm) + (Fpc)$

OR IF BOAT WILL NOT CARRY A MOTOR:

$$(Ft) = (Fb) + (Fpc)$$

With Motor (Ft) = -1.0 + 1.0 + 1.0
(Ft) = 1 cubic foot

Without Motor (Ft) = -1.0 + 1.0
(Ft) = 0

Note: Because this boat is made of plywood and does not carry an outboard motor no additional flotation is required.

Total flotation material needed:

1 cubic foot (with motor)

0 (without motor)

Now turn to page 26 which describes where to install your flotation.

EXAMPLE B - - 14-FOOT ALUMINUM RUNABOUT (OR JONBOAT)

Assume Hull Weight is:	220 lbs.
Assume Deck Weight is:	60 lbs.
Assume Maximum Persons Capacity is:	400 lbs.
Assume Maximum Weight Capacity is:	800 lbs.
Assume Maximum Horsepower is:	30 HP

**STEP I
DETERMINE TOTAL FLOTATION MATERIAL NEEDED TO
SUPPORT SWAMPED BOAT (Fb)**

Formula:
$$(Fb) = \frac{(Wh \times K) + Wd}{B}$$

Where:

Wh =	Dry Weight of Hull =	220 lbs.
Wd =	Dry Weight of Deck =	60 lbs.
	(Wd normally would include everything above the gunwales including windshield, hardware and accessories)	
K =	Conversion Factor for Aluminum =	.63
	(See Appendix B for other materials)	
B =	Buoyancy of Flotation Material in pounds per cubic foot =	60.4
	(See page 39)	

$$(Fb) = \frac{(220 \times .63) + 60}{60.4} = \frac{(138.60) + 60}{60.4} = \frac{198.60}{60.4}$$

$$= 3.28 \text{ rounded up} = 4.0$$

Flotation to support the boat = 4.0 cubic feet

**STEP II
DETERMINE TOTAL FLOTATION MATERIAL NEEDED TO
SUPPORT SWAMPED MOTOR (Fm)**

Formula: $(Fm) = \frac{S}{B}$

Where:

S = Total Swamped Weight = 143 lbs.
(locate in Table 1 the boat's maximum horsepower)

B = Buoyancy of Flotation Material in pounds per cubic foot = 60.4
(See page 39)

$$(Fm) = \frac{143}{60.4} = 2.36 \text{ rounded up} = 3.0$$

Flotation to support the motor = 3.0 cubic foot

**STEP III
DETERMINE FLOTATION MATERIAL NEEDED TO SUPPORT
PERSONS CAPACITY (Fpc)**

Formula: $(Fpc) = \frac{.5 (\text{first 550 lbs. PC}) + .125 (\text{remaining PC}) + .25 (C - PC)}{B}$

Where:

PC = Maximum Persons Capacity in pounds = 450 lbs.

C = (Maximum Weight Capacity - Total Dry Weight) = 485 lbs.
(see Column 6 of Table 1)

B = Buoyancy of Flotation Material in pounds per cubic foot = 60.4
(see page 39)

$$(Fpc) = \frac{.5 (450) + .125 (0) + .25 (575 - 450)}{60.4} = \frac{225 + 0 + 31.25}{60.4}$$

$$= \frac{256.25}{60.4} = 4.24 \text{ rounded up} = 5.0 \text{ cubic feet}$$

Flotation to support persons capacity = 5.0 cubic foot

**STEP IV
DETERMINE TOTAL FLOTATION MATERIAL NEEDED (Ft)**

Formula: $(Ft) = (Fb) + (Fm) + (Fpc)$

$$(Ft) = 4.0 + 3.0 + 5.0$$

$$(Ft) = 12 \text{ cubic feet}$$

Total flotation material needed = 12 cubic feet

Now turn to page 26 which describes where to install your flotation.

EXAMPLE C - - 17-FOOT FIBERGLASS RUNABOUT

Assume Hull Weight is:	800 lbs.
Assume Deck Weight is:	200 lbs.
Assume Maximum Persons Capacity is:	900 lbs.
Assume Maximum Weight Capacity is:	1400 lbs.
Assume Maximum Horsepower is:	85 HP

**STEP I
DETERMINE TOTAL FLOTATION MATERIAL NEEDED TO
SUPPORT SWAMPED BOAT (Fb)**

Formula:
$$(Fb) = \frac{(Wh \times K) + Wd}{B}$$

Where:

Wh =	Dry Weight of Hull =	800 lbs.
Wd =	Dry Weight of Deck =	200 lbs.
	(Wd normally would include everything above the gunwales including windshield, hardware and accessories)	
K =	Conversion Factor for Fiberglass =	.33
	(See Appendix B)	
B =	Buoyancy of Flotation Material in pounds per cubic foot =	60.4
	(See page 39)	

$$(Fb) = \frac{(800 \times .33) + 200}{60.4} = \frac{(264) + 200}{60.4} = \frac{464}{60.4}$$

$$= 7.68 \text{ rounded up} = 8.0$$

Flotation to support the boat = 8.0 cubic feet

**STEP II
DETERMINE TOTAL FLOTATION MATERIAL NEEDED TO
SUPPORT SWAMPED MOTOR (Fm)**

Formula:
$$(Fm) = \frac{S}{B}$$

Where:

S = Total Swamped Weight = 235 lbs.
(locate in Table 1 the boat's maximum horsepower)

B = Buoyancy of Flotation Material in pounds per cubic foot = 60.4
(See page 39)

$$(F_m) = \frac{235}{60.4} = 3.89 \text{ rounded up} = 4.0$$

Flotation to support the motor = 4.0 cubic feet

**STEP III
DETERMINE FLOTATION MATERIAL NEEDED TO
SUPPORT PERSONS CAPACITY (F_{pc})**

Formula: $(F_{pc}) = \frac{.5 (\text{first 550 lbs. PC}) + .125 (\text{remaining PC}) + .25 (C - PC)}{B}$

Where:

PC = Maximum Persons Capacity in pounds = 900 lbs.

C = (Maximum Weight Capacity - Total Dry Weight) = 975 lbs.
(see Column 6 of Table 1)

B = Buoyancy of Flotation Material in pounds per cubic foot = 60.4
(see page 39)

$$(F_{pc}) = \frac{.5 (550) + .125 (350) + .25 (1400 - 975)}{60.5} = \frac{275 + 43.75 + 106.25}{60.4}$$

$$= \frac{425}{60.4} = 7.03 \text{ rounded up} = 8.0 \text{ cubic feet}$$

Flotation to support persons capacity = 8.0 cubic feet

**STEP IV
DETERMINE TOTAL FLOTATION MATERIAL NEEDED (F_t)**

Formula: $(F_t) = (F_b) + (F_m) + (F_{pc})$

$$(F_t) = 8 + 4 + 8$$

$$(F_t) = 20 \text{ cubic feet}$$

Total flotation material needed = 20 cubic feet

Now turn to page 26 which describes where to install your flotation.

EXAMPLE D - - 19-FOOT FIBERGLASS INBOARD

Assume Hull Weight is:	700 lbs.
Assume Deck Weight is:	200 lbs.
Assume Maximum Persons Capacity is:	1000 lbs.
Assume Maximum Weight Capacity is:	1400 lbs.
Assume Maximum Horsepower is:	165 HP (700 lbs.)

**STEP I
DETERMINE FLOTATION MATERIAL NECESSARY TO
SUPPORT SWAMPED BOAT (Fb)**

NOTE: IN THIS EXAMPLE HULL WEIGHT IS DIVIDED INTO TWO SEPARATE WEIGHTS. SINCE THE BOAT IS MADE OF LARGE QUANTITIES OF BOTH WOOD AND FIBERGLASS.

Formula: $(Fb) = \frac{(Wh \times K) + (Wh \times K) + Wd}{B}$

Where:

Wh =	Dry Weight of Hull (fiberglass) =	500 lbs.
Wh =	Dry Weight of Hull (wood) =	200 lbs.
K =	Conversion Factor for Fiberglass =	.33
	(See Appendix B for other materials)	
K =	Conversion Factor for Plywood =	-.81
	(See Appendix B for other materials)	
Wd =	Dry Weight of Deck =	200 lbs.
B =	Buoyancy of Flotation Material in pounds per cubic foot =	60.4
	(See page 39)	

$$(Fb) = \frac{(500 \times .33) + (200 \times -.81) + 200}{60.4} = \frac{(165) + (-162) + 200}{60.4} = \frac{203}{60.4}$$

= 3.36 rounded up = 4.0

Flotation to support the boat = 4.0 cubic feet

**STEP II
DETERMINE FLOTATION MATERIAL NECESSARY TO
SUPPORT SWAMPED MOTOR (Fm)**

Formula: $(Fm) = \frac{S}{B}$

Where:

S = 75% of engine weight
(including drive unit, transmission, shaft, propeller and battery)
B = Buoyancy of Flotation Material in pounds per cubic foot = 60.4
(See page 38)

$$(Fm) = \frac{.75 (700)}{60.4} = \frac{525}{60.4} = 8.69 \text{ rounded up} = 9.0$$

Flotation to support the motor = 9.0 cubic feet

**STEP III
DETERMINE FLOTATION MATERIAL NEEDED TO SUPPORT
PERSONS CAPACITY (Fpc)**

Formula: $(Fpc) = \frac{.5 (\text{first } 550 \text{ lbs. PC}) + .125 (\text{remaining PC}) + .25 (C - PC)}{B}$

Where:

PC = Maximum Persons Capacity in pounds = 1000 lbs.
C = (Maximum Weight Capacity - Total Dry Weight) = 400 lbs.
(1400 - 700)
B = Buoyancy of Flotation Material in pounds per cubic foot = 60.4
(see page 39)

$$(Fpc) = \frac{.5 (550) + .125 (450) + .25 (700)}{60.4} = \frac{275 + 56.25 + 175}{60.4}$$
$$= \frac{506.25}{60.4} = 8.39 \text{ rounded up} = 9.0 \text{ cubic feet}$$

Flotation to support persons capacity = 9.0 cubic feet

**STEP IV
DETERMINE TOTAL FLOTATION MATERIAL NEEDED (Ft)**

Formula: $(Ft) = (Fb) + (Fm) + (Fpc)$

$$(Ft) = 4.0 + 9.0 + 9.0 = 22 \text{ cubic feet}$$

Total flotation material needed = 22 cubic feet

Now turn to page 26 which describes where to install your flotation.

LOCATION OF FLOTATION

Now that you know how much flotation you need to support the weight of your boat (F_b), the weight of the motor (F_m), and the weight of the rated persons capacity (F_{pc}), we'll explain the importance of symmetrical distribution. For Level Flotation the flotation material (foam or air chambers) must be located in or on the boat in such a way that it supports the boat, the motor and the passengers in a level attitude when the boat is swamped.

The flotation for the boat alone must be placed symmetrically about the midpoint and centerline of the boat.

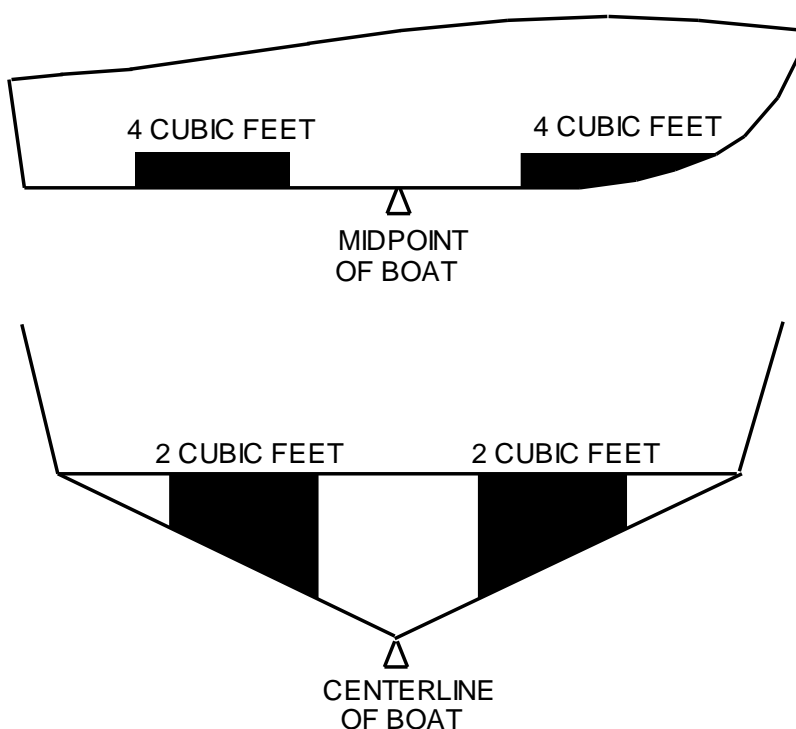

By symmetrically, we mean creating a balance. Two cubic feet of flotation material installed two feet forward of the midpoint may be balanced by two cubic feet of flotation installed two feet aft of the midpoint. Equally, two cubic feet of flotation installed two feet to the right of the centerline may be balanced by two cubic feet of flotation installed two feet to the left of the centerline.

This same balance can also be applied to unequal amounts and unequal distances providing the two remain proportional: Two cubic feet of flotation two feet from the midpoint may be balanced by one cubic foot of flotation installed four feet from the midpoint.

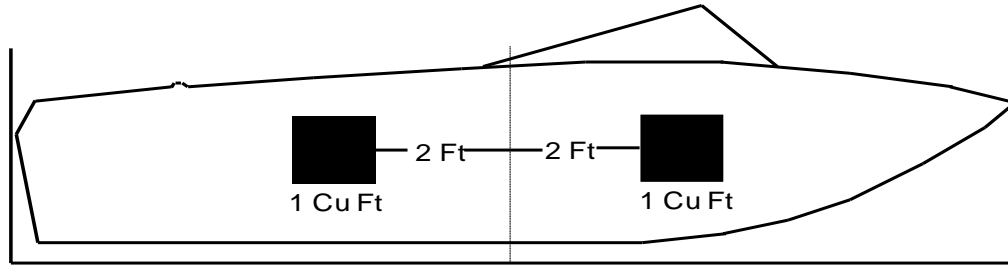

EQUAL QUANTITIES
EQUAL DISTANCES
FROM MIDPOINT

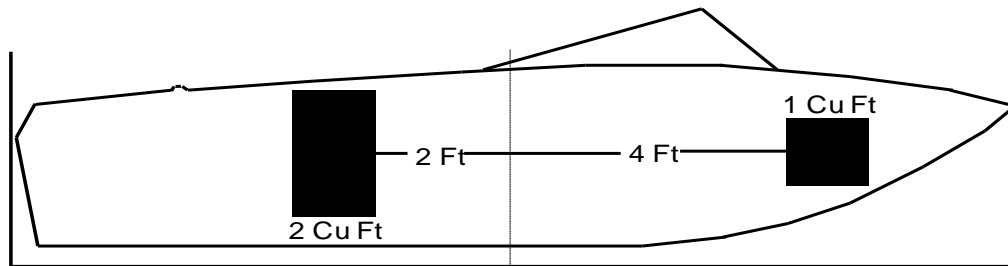

UNEQUAL QUANTITIES
TWICE THE QUANTITY - HALF THE DISTANCE
FROM MIDPOINT

The flotation necessary to support the motor must be placed symmetrically about the area in which it will be located. On outboard powered boats larger than 15 feet, the flotation must be installed within 3 feet of the transom and on boats less than 15 feet, within 30 inches of the transom.

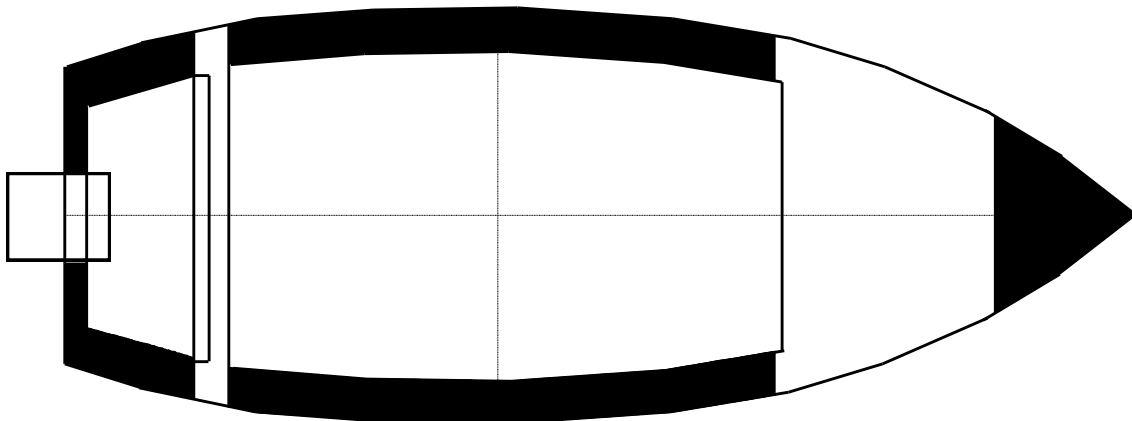

The Flotation necessary to support the maximum persons capacity must be installed symmetrically about the passenger carrying area as far from the centerline and as close to the gunwales as possible.

FLOTATION MATERIAL TO SUPPORT AND BALANCE HULL

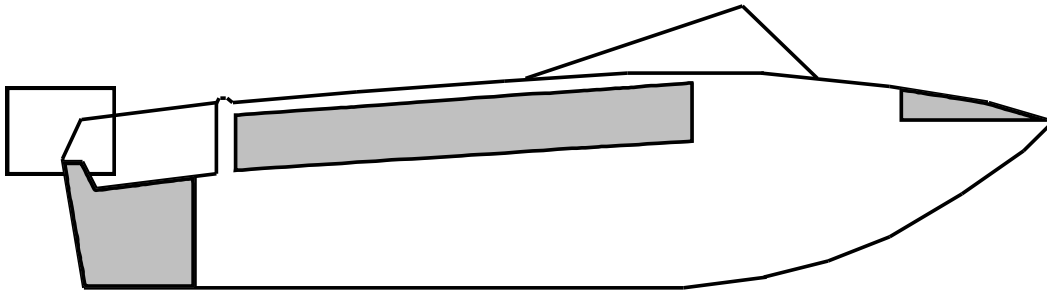

LEVEL FLOTATION FOR TYPICAL RUNABOUT

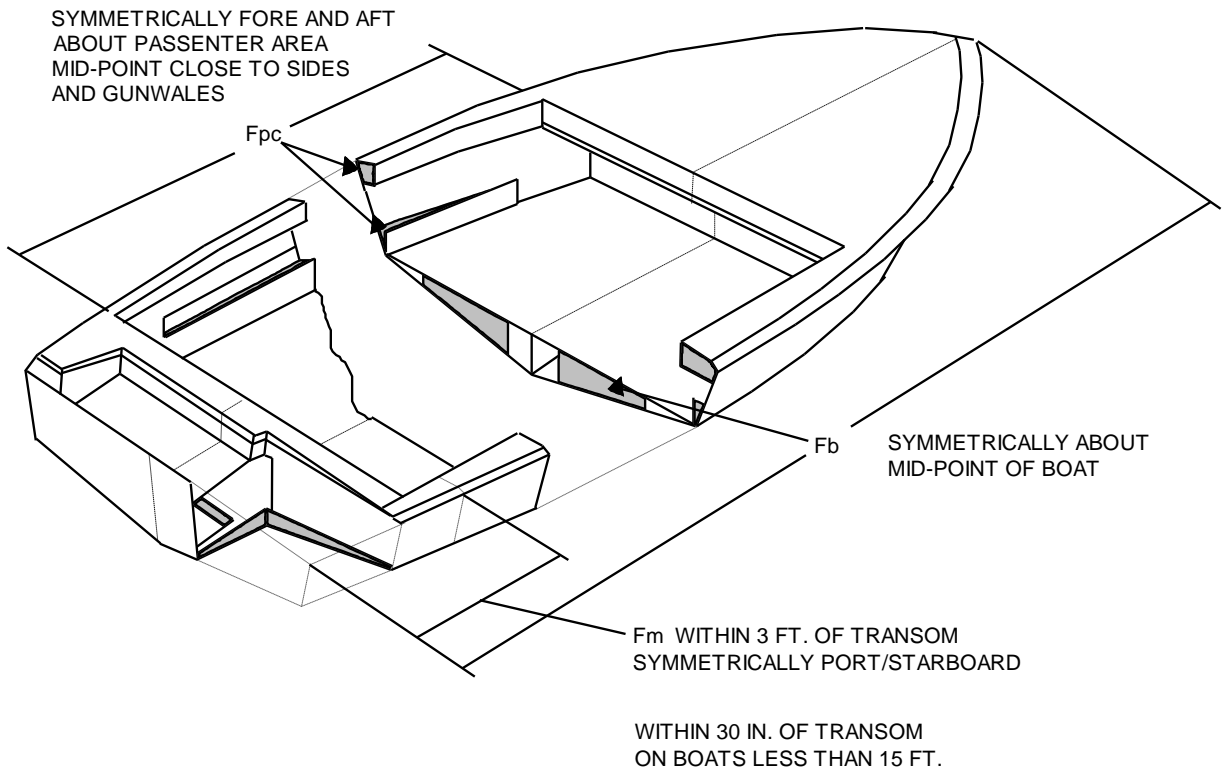

RETROFIT OF LEVEL FLOTATION ON BOATS EQUIPPED WITH BASIC FLOTATION

Installing Level Flotation in boats equipped with Basic Flotation requires determining where the Basic Flotation is installed, because as we said earlier, the flotation must be placed “symmetrically” in order to make the boat float level when swamped. In small outboard runabouts and jonboats with sealed seats, the flotation is usually located inside the seats. On larger boats Basic Flotation is usually located beneath the cockpit floor or underneath the forward deck.

The Basic Flotation regulations require that some portion of the boat remain above the surface of the water, so your boat already has enough flotation to support the boat. You can disregard Step I in the Calculations section and go on and complete steps II, III and IV.

The additional flotation you add to support the motor and maximum persons capacity must be placed around the motor (in the rear corners of runabouts and jonboats) and high in the sides of the passenger carrying area.

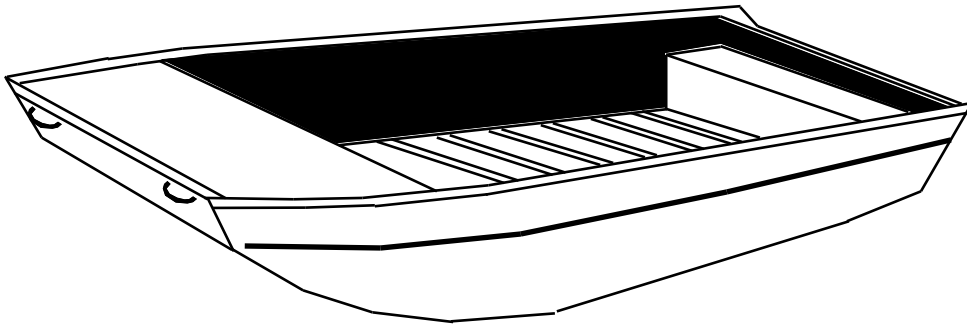
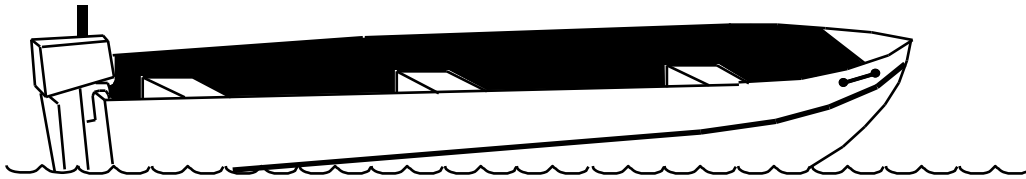

More complete information and illustrations of the Level Flotation Standard may be obtained by requesting a copy of the Level Flotation Compliance Guideline from the American Boat and Yacht Council, 405 Headquarters Drive, Suite 3, Millersville, MD 21108. There is a \$10.00 charge for the guideline (which includes postage and handling) payable by check or money order.

VENTILATION

The Ventilation System Standard applies to all boats that have permanently installed gasoline engines for electrical generation (generators), mechanical power or propulsion (inboards and sterndrives). In some instances the standard also may apply to boats powered by outboards (such as an outboard powered boat with a fuel tank permanently installed in a compartment).

GENERAL:

With certain exceptions, the Coast Guard Ventilation System Standard requires:

A natural ventilation system consisting of openings and ducts for any compartment which contains, or is connected to another compartment which contains, a permanently installed gasoline engine or fuel tank, unless certain portions of each of the compartments are "open to the atmosphere."

A powered ventilation system consisting of an exhaust blower and duct system must also be provided for each compartment in a boat that contains a permanently installed gasoline engine with a cranking motor (starter). "Open to the atmosphere" means a compartment that has at least 15 square inches of open area directly exposed to the atmosphere for each cubic foot of net compartment volume.

NATURAL VENTILATION

Except for compartments "open to the atmosphere," a natural ventilation system must be provided for each compartment in a boat that –

- contains a permanently installed gasoline engine;
- contains a permanently installed fuel tank and an electrical component that is not ignition protected in accordance with the Electrical System Standard (see page 35);
- contains a fuel tank that vents into that compartment; or
- contains a non-metallic fuel tank.

The "Natural Ventilation System" must consist of:

- (1) supply opening(s) or duct(s) from the atmosphere or from a ventilated compartment or from a compartment that is ventilated to the atmosphere; and
 - (2) exhaust opening(s) into another ventilated compartment or exhaust duct(s) to the atmosphere.
- Each supply opening must be located on the exterior surface of the boat:

- Each exhaust opening or exhaust duct must originate in the lower third of the compartment.
- Each supply opening or supply duct and each exhaust opening or exhaust duct in a compartment must be above the normal accumulation of bilge water.
- The minimum internal cross sectional area of each supply opening or duct and exhaust opening or duct must exceed 3.0 square inches.

STANDARD DUCT SIZES	
4.91 sq. in.	(2.5 in. diam.)
7.07 sq. in.	(3 in. diam.)
9.62 sq. in.	(3.5 in. diam.)
12.75 sq. in.	(4 in. diam.)
19.63 sq. in.	(5 in. diam.)

AREA OF EACH INTAKE OPENING
OR DUCT AND EACH EXHAUST
OPENING OR DUCT IN SQUARE
INCHES

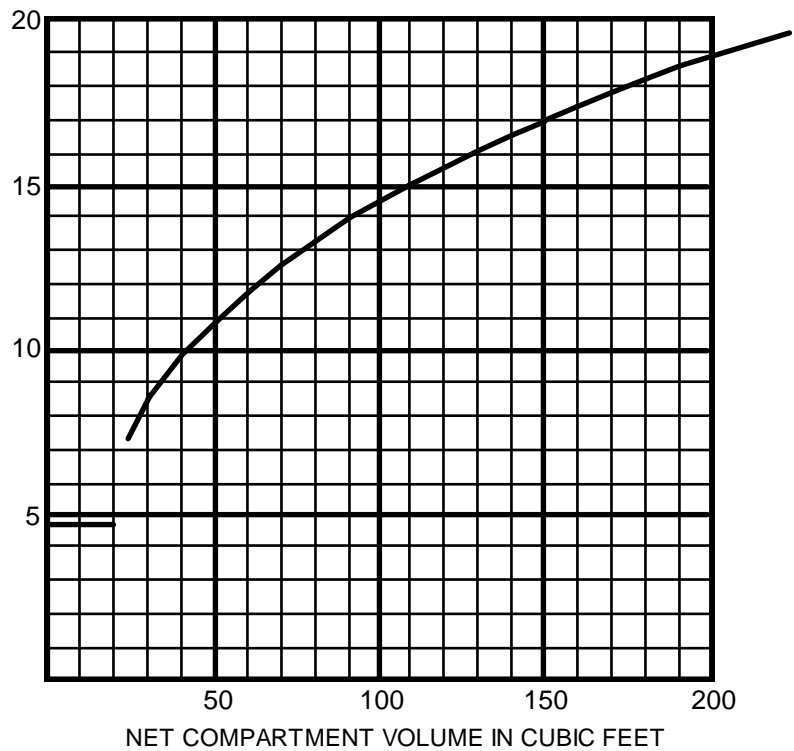

For example:

19 foot Fiberglass Inboard

Assume Engine compartment is 5 ft. x 3 ft. x 4 ft. =

60.00 cu. ft.

Assume engine is a 6 cyl. In line =

3.50 cu. ft.

Battery volume =

.50 cu. ft.

60.00 cu. ft. (engine compartment volume)
- 3.50 cu. ft. (less volume of 6 cyl. engine)
56.50 cu. ft.
- .50 cu. ft. (less volume of 1 battery)
56.00 cu. ft. net compartment volume

Using the graph on the previous page, the engine compartment in our example would have to have openings or ducts totaling 12.5 square inches cross sectional area.

Each exhaust blower or combination of blowers must be rated at an air flow capacity not less than that computed by the formulas given in the graph below:

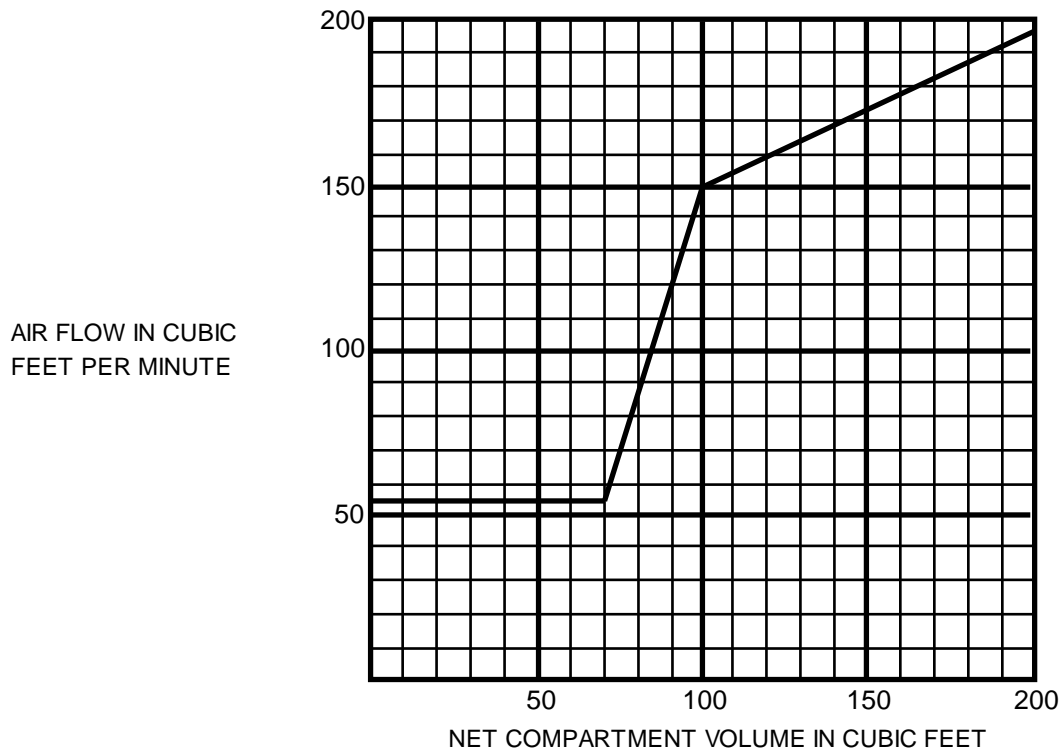

Each intake duct for an exhaust blower must be in the lower one-third of the compartment and above the normal level of accumulated bilge water.

BLOWER LABEL:

Each boat that is required to have an exhaust blower must have a label that is located in plain view of the boat operator, as close as possible to each ignition switch, that states:

“ – WARNING –
GASOLINE VAPORS CAN EXPLODE.
BEFORE STARTING ENGINE OPERATE BLOWER
FOR 4 MINUTES AND CHECK ENGINE COMPARTMENT
BILGE FOR GASOLINE VAPORS.”

More complete information and illustrations of the Ventilation System Standard may be obtained by requesting a copy of the Ventilation System Compliance Guideline from the American Boat and Yacht Council, 3069 Solomon’s Island Road, Edgewater, MD 21037-1416. There is a \$10.00 charge (which includes postage and handling) for the guideline payable by check or money order.

FUEL AND ELECTRICAL SYSTEM STANDARDS

The Fuel and Electrical System Standards apply to all boats that have permanently installed gasoline engines for electrical generation (generators), mechanical power or propulsion (inboards and sterndrives). The standards do not apply to outboards or portable equipment.

The purpose of the Fuel and Electrical System Standards is to reduce the probability of gasoline fuel or vapor leakage and potential electrical ignition sources which could otherwise cause a fire or explosion.

The following is a summary of the major requirements of the Fuel and Electrical System Standards (see bottom of next page for additional sources of information).

GASOLINE FUEL SYSTEMS

1. Permanently installed gasoline fuel tanks must meet certain requirements. They must bear a label containing the manufacturer's name and address and the statement, "This tank has been tested under 33 CFR 183.580," which indicates that the tank passes a required static pressure test. Also, some fuel tanks cannot be permanently installed in the forward part of the boat. These tanks must also bear the statement, "Must be installed aft of the boat's half length."
2. Each fuel tank vent must have a flame arrester that can be cleaned unless the vent is itself a flame arrester. There must be some means of cleaning the flame arrester to prevent it from becoming clogged and therefore inoperable.
3. Diaphragm type fuel pumps must not leak fuel from the pump if the primary diaphragm fails. This requirement calls for a means to prevent fuel from leaking into the interior of the boat if the main diaphragm fails.
4. Electrically operated fuel pumps must not operate except when the engine is running.
5. Carburetors must be intended for marine use.
6. Except when used for a tank fill line, each spud, pipe or hose fitting used with hose clamps must have a bead, flare or series of grooves forming closed rings to prevent the hose from sliding off the fitting.
7. Each metallic fuel line connecting the fuel tank with the fuel inlet connection on the engine must be made of seamless annealed copper, nickel-copper or copper-nickel.
8. Each hose between the fuel pump and the carburetor must be "USCG Type A1" hose. Each hose used for a vent line or fill line must be "USCG Type A1" or "USCG Type A2" hose.

9. Each hose from the fuel tank to the fuel inlet connection on the engine must be "USCG Type A1" hose.
10. Each fuel line from the fuel tank to the fuel inlet connection on the carburetor must be above the level of the tank top or have an anti-siphon device or an electrically operated fuel stop valve.

ELECTRICAL SYSTEMS

1. Each battery must be installed to that metallic objects cannot come into contact with the _____ battery terminals.
2. Hydrogen gas discharged by a battery must not accumulate in the boat.
3. Alternators and starter motors must be intended for marine use.
4. Each conductor must be insulated stranded copper wire.
5. Each electrical component in the engineroom and bilges must be fully enclosed or otherwise protected to prevent the ignition of gasoline vapors.
6. Each ungrounded current carrying conductor must be protected by a manually reset, trip-free circuit breaker or fuse.
7. Each conductor or group of conductors must be supported by clamps or straps not more than 18 inches apart, unless the conductor or group of conductors is enclosed in a rigid duct or conduit. The clamps, straps, ducts or conduits must be designed to prevent chafing or damage to the conductor insulation.
8. A soldered connection must not be the sole means of connection between two or more conductors or between a conductor and a connector. Crimped terminals and connectors are preferred.
9. Low voltage conductors must comply with SAE Standard J1127 and J1128 and the insulation temperature rating of SAE J378b or UL Standard 1426.

More complete information and illustrations of the requirements of the Fuel and Electrical System Standards may be obtained by requesting a copy of:

- a. Fuel System Compliance Guideline; or
- b. Electrical System Compliance Guideline

From the American Boat and Yacht Council, 3069 Solomon's Island Road, Edgewater, MD 21037-1416.

CAPACITY INFORMATION

Builders of monohull boats less than 20 feet in length except sailboats, canoes, kayaks and inflatables are required to display a U.S. Coast Guard Maximum Capacities label where it is visible to the operator when getting the boat underway. The Maximum Capacities label displays the Maximum Horsepower Capacity for outboard powered boats, the Maximum Persons Capacity in pounds and number of persons, and the Maximum Weight Capacity (persons, outboard motor and gear for boats powered by outboards; persons and gear for manually propelled boats and boats powered by inboards). The U.S. Coast Guard Maximum Capacities label is intended to give the operator of the boat a guide in determining the weights and horsepower (if applicable) the boat can safely carry.

Below is an illustration of a Maximum Capacities label. On a similar label you should write in the Maximum Horsepower Capacity (if applicable), the Maximum Persons Capacity in pounds, the Maximum Persons Capacity in persons and the Maximum Weight Capacity you calculated at the beginning of this pamphlet.

Permanently attach the label (with a coat of fiberglass resin for example) to your boat near the operator's position. Then you or anyone who operates your boat will know how much weight and how much horsepower your boat can safely carry.

NOTE:

Since the calculation of a maximum horsepower capacity is not required for boats that are not designed for use with a motor or are powered by inboards and sterndrives, the maximum horsepower capacity block should be left blank on the capacity label for those boats.

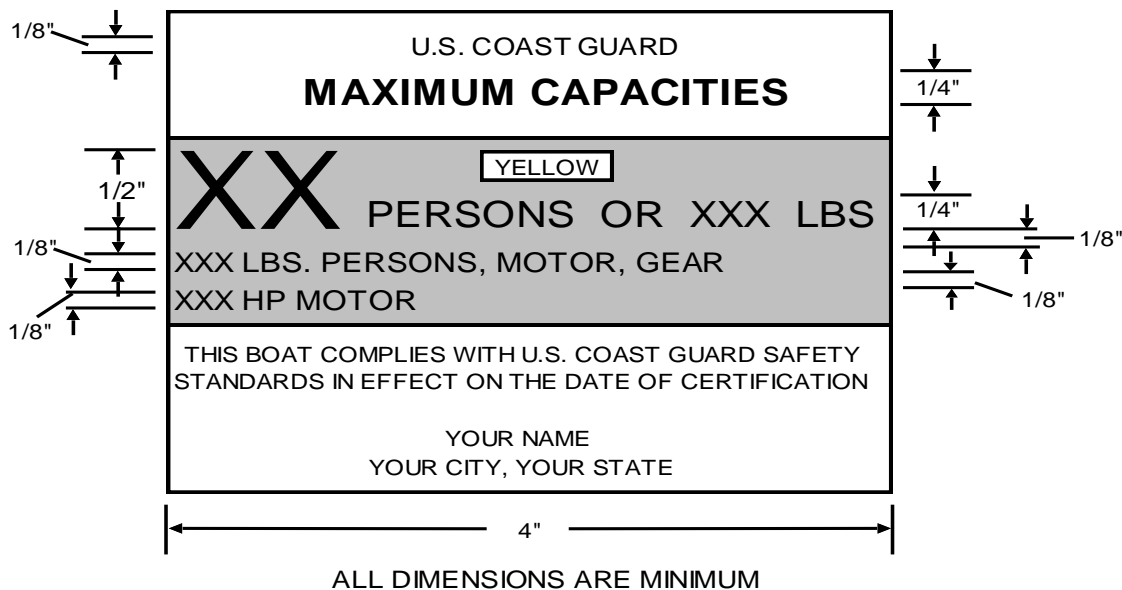

HULL IDENTIFICATION NUMBERS

All boats must bear two Hull Identification Numbers (HINs). The HIN is like a serial number. It is a unique number that identifies your boat. The HIN is not the same as the State registration number which may also be required to be displayed on the bow of your boat. **DO NOT CONFUSE THESE TWO NUMBERS.** The HIN is a Federal requirement; your boat's registration number is a State requirement similar to the license plate on your car.

When you start to build your boat or while you are building it, write to your State boating agency (their addresses appear at the end of this pamphlet), tell them that you are building a boat and that you need a Hull Identification Number (HIN). You can also inquire about your registration number at the same time. Not all State agencies issue HINs, but those that do not will probably refer you to the nearest Coast Guard District Office (their addresses also appear at the end of this pamphlet).

When you receive your HIN it will look something like this:

ABZ98765E393

The first two letters are an abbreviation for the State in which you live. The "Z" indicates that the first two letters indicate a State and not an abbreviation for the name of a commercial manufacturer. The next five characters (numbers or letters) are a serial number which uniquely identifies your boat. The last four characters represent the month and year your boat was built. In the HIN above the boat was built in May 1993.

TWO HINS MUST BE PERMANENTLY DISPLAYED ON YOUR BOAT

THE PRIMARY HIN

On boats with transoms: The primary HIN must be affixed to the starboard (right) side of the transom within two inches of the top of the transom, gunwale or hull and deck joint, whichever is lowest.

On boats without transoms or on boats on which it would be impractical to use the transom: The primary HIN must be affixed to the starboard (right) outboard side of the hull, aft, within one foot of the stern and within two inches of the top of the hull side, gunwale or hull and deck joint, whichever is lowest.

On catamarans and pontoon boats which have readily replaceable hulls: The primary HIN must be affixed to the aft crossbeam within one foot of the starboard (right) hull attachment.

NOTE;

IF THE HIN WOULD NOT BE VISIBLE BECAUSE OF RAILS, FITTINGS OR OTHER ACCESSORIES, IT MUST BE AFFIXED AS NEAR AS POSSIBLE TO THE LOCATIONS DESCRIBED ABOVE.

THE SECONDARY HIN

A secondary HIN must be affixed in an unexposed location inside the boat or beneath a fitting or item of hardware.

For example: On a dinghy you could place the secondary HIN on the inside surface of the hull beneath a seat or thwart or underneath the rubrail. On runabouts the secondary HIN could be placed on the inside surface of the hull up forward under the forward deck, behind the remote controls, or underneath a cleat. The idea here is to place the secondary HIN in a place that is unexposed that someone would not normally be able to find unless they really looked for it closely. Do not put the second HIN on a part of the boat that is easily or normally removable.

The secondary HIN will help the authorities identify your boat if a thief removes or damages the primary HIN you affix to the transom.

PERMANENTLY AFFIXED

Each of your HINs must be permanently affixed. They must be carved, burned, stamped, embossed, molded, bonded or otherwise permanently affixed so that alteration, removal or replacement would be obvious. If the HINs are on separate plates, the plates must be fastened in such a way that their removal would normally cause some scarring of or damage to the surrounding hull area. For example, if you use a separate plate, use wood screws or pop rivets and epoxy to affix it to the hull.

SIZE

The letters and numbers in your HIN must be at least ¼ inch high. They can be larger, but not smaller.

CERTIFICATION

Boats that are subject to Coast Guard safety standards must bear a label which contains the statement, "THIS BOAT COMPLIES WITH U.S. COAST GUARD SAFETY STANDARDS IN EFFECT ON THE DATE OF CERTIFICATION," and the name and address of the manufacturer. The certification statement, which indicates that the boat complies with applicable safety standards in effect, may be printed on a separate label or combined into one label with the U.S. Coast Guard Maximum Capacities label.

APPENDIX A

FLOTATION MATERIALS AND THEIR INSTALLATION

Back in the Calculations section of the Level Flotation Standard which began on page 17 were four examples to be used as guides for determining how much flotation your boat requires. The symbol, "B," in Steps I, II and III in each example represents the buoyancy of flotation material you choose to use in pounds per cubic foot. A cubic foot of enclosed air will provide 62.4 pounds of buoyancy, so if you are using air chambers or air bags for your flotation, "B" in each of the steps is equal to 62.4.

If you are using foam for your flotation material, to calculate the buoyancy, you subtract its density per cubic foot (its weight per cubic foot) from 62.4. If you are using 2 pound density foam, 2 from 62.4 equals 60.4. Two pound density foam provides 60.4 pounds of buoyancy per cubic foot, and so on.

Obviously, the flotation material you select must be able to withstand the environment in which it is placed. Foams that are not resistant to oil and gasoline cannot be placed near the engine or in the bilges. Similarly, foams that deteriorate under ultraviolet light cannot be left exposed to sunlight, and foams that are brittle and chip easily cannot be left exposed where they could be damaged by passengers or normal wear and tear on the boat.

Foams may be purchased from marinas, marine supply stores, hardware stores and some lumberyards. Most foams come in blocks, but some are available in a two liquid mix. Then you go to purchase your foam, ask the sales people whether it can be used in a marine environment; whether it is durable or brittle. These considerations are necessary in deciding where you can install your foam without causing it to deteriorate.

The following is a list of various types of foams (with a brief description of air chambers), their resistance to deterioration and how they can be installed.

POLYSTYRENE (Styrofoam for example) is the least expensive foam available, but it will dissolve upon contact with gasoline, is brittle and will crumble when left exposed to sunlight. Builders who choose to use Polystyrene foams should cover them with plywood, vinyl or another material, or enclose the foam in compartments where it is not exposed to abrasion, the elements or sunlight. Polystyrene should not be installed near the engine or bilges.

POLYURETHANE, which is slightly more expensive than Polystyrene, is available in many varieties, each one suitable to a different type of application. Although many Polyurethane foams are resistant to gasoline, few are resistant to sunlight, and they cannot be installed in areas where they are exposed. Polyurethane foams are available

in blocks as well as a two part mix. Blocks can be installed in compartments, beneath the cockpit floor, the gunwales or the deck. The two liquid mix variety can be poured into molds to fit specific areas or can be poured into confined spaces and compartments.

BLACK POLYETHYLENE (Ethafom for example) is the most expensive of foams that are readily available, but it has certain advantages the others do not. It can be installed anywhere in the boat. It is resistant to gasoline and other compounds, and is ideal for use around the motorwell or in the bilges. It is very flexible and resistant to abrasion. It can even be installed on the outside of dinghies, small skiffs and jonboats where more brittle foams would crumble from abrasion. Black Polyethylene can be installed beneath the gunwales, inside compartments or can be attached to the boat with bolts and large washers.

AIR CHAMBERS are an alternative to foam flotation material. Builders who choose to use air chambers should remember that a part of the hull cannot be used as part of an air chamber, since damage to the hull in the form of a crack or puncture would also damage the air chamber and eliminate any buoyancy it provided. Rubber or vinyl air bags can also be used, and although they are reasonably easy to install there are some drawbacks. They must be securely confined to keep them from breaking away from the hull when the boat becomes swamped and they must be placed in such a way that they cannot be punctured by sharp objects. Air bags might also take up necessary stowage space and they may be more difficult to locate "symmetrically" than if foam is used.

APPENDIX B

MATERIAL CONVERSION FACTORS

Lead	0.91
Bronze	0.89
Brass	0.88
Stainless Steel	0.88
Cast Iron	0.86
Aluminum	0.63
Ferro Cement	0.58
Rubber	0.34
Fiberglass	0.33
Kevlar	0.24
Plexiglas – Lucite	0.17
A.B.S.	0.11
Teak	-0.01
Oak – White	-0.18
Oak	-0.56
Blandex	-0.70
Mahogany – Philippine	-0.72
Mahogany – Honduras	-0.78
Ash	-0.78
Yellow Pine	-0.81
Fir Plywood	-0.81
Mahogany Plywood	-0.83
Royalex	-0.95
Mahogany – African	-0.96
Fir	-0.96
Cedar – Port Orford	-1.08
Pine – White	-1.38
Cedar – Western Red	-1.70
Cedar – White	-1.95
Cork	-3.17
Balsa – End Grain	-5.24

APPENDIX C

Table 1

**WEIGHTS (Pounds) OF OUTBOARD MOTOR AND
RELATED EQUIPMENT
FOR VARIOUS BOAT HORSEPOWER RATINGS**

Boat Horsepower Rating	Motor and Control Weight		Battery Weight		Full Portable Fuel Tank Weight	1=3=5
	Dry	Swamped	Dry	Submerged		
	Column					
	1	2	3	4	5	6
0.1 to 2	25	20	-	-	-	25
2.1 to 3.9	40	34	-	-	-	40
4.0 to 7	60	52	-	-	25	85
7.1 to 15	90	82	20	11	50	160
15.1 to 25	125	105	45	25	50	220
25.1 to 45	170	143	45	25	100	315
45.1 to 60	235	195	45	25	100	380
60.1 to 80	280	235	45	25	100	425
80.1 to 145	405	352	45	25	100	550
145.1 to 275	430	380	45	25	100	575
275.1 and up	605	538	45	25	100	750
Transoms Designed for Twin Motors						
50.1 to 90	340	286	90	50	100	530
90.1 to 120	470	390	90	50	100	660
120.1 to 160	560	470	90	50	100	750
160.1 to 290	810	704	90	50	100	1000
290.1 to 550	860	760	90	50	100	1050
550.1 and up	1210	1076	90	50	100	1400

APPENDIX D

DESIGN GUIDELINE FOR SURVIVAL HANDLES

APPLICABILITY

This design guideline applies to monohull boats less than 20 feet in length except sailboats, canoes, kayaks, inflatables, raceboats, submersibles and amphibious vehicles.

Survival handles are not required for boats equipped with Level Flotation; however, they are strongly recommended as a safety feature aboard boats equipped with Basic Flotation.

INTRODUCTION

The Coast Guard and other groups who advocate boating safety always say:

“If you have an accident, **STAY WITH THE BOAT**, and don’t panic.”

But because a boating accident can terrify an experienced boater as easily as a novice, survivors of boating accidents frequently think they will be safer if they can get to shore. Many drown trying to swim there.

Some boats that are not equipped with Level Flotation, particularly outboards, have a tendency to capsize when they become filled with water and float upside down leaving only a small part of the bow above the surface of the water. In this position there are few parts of the boat survivors can cling to until assistance arrives. The shore, however, which looks so close, is really much farther away.

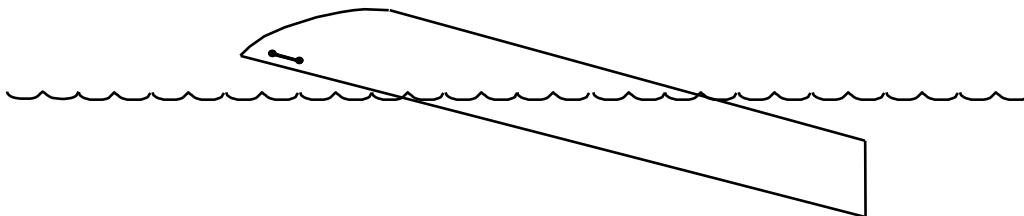

In order to give the survivors of boating accidents a better sense of security, this guideline explains how to install survival handles as an additional _____ on boats equipped with only Basic Flotation. These handles _____ survivors of boating accidents to stay with the boat until help arrives by giving them something they can hang onto comfortably.

INSTALLATION PROCEDURE

Wood, plastic or metal handles can be used, and although no particular style or dimensions are specified, the handles should be smooth and large enough so that they are comfortable for a person in the water to hang onto.

Because their strength depends upon the manner in which they are installed, the handles should be through-bolted to the boat with backing plates (3/8 inch plywood or 1/8 inch aluminum).

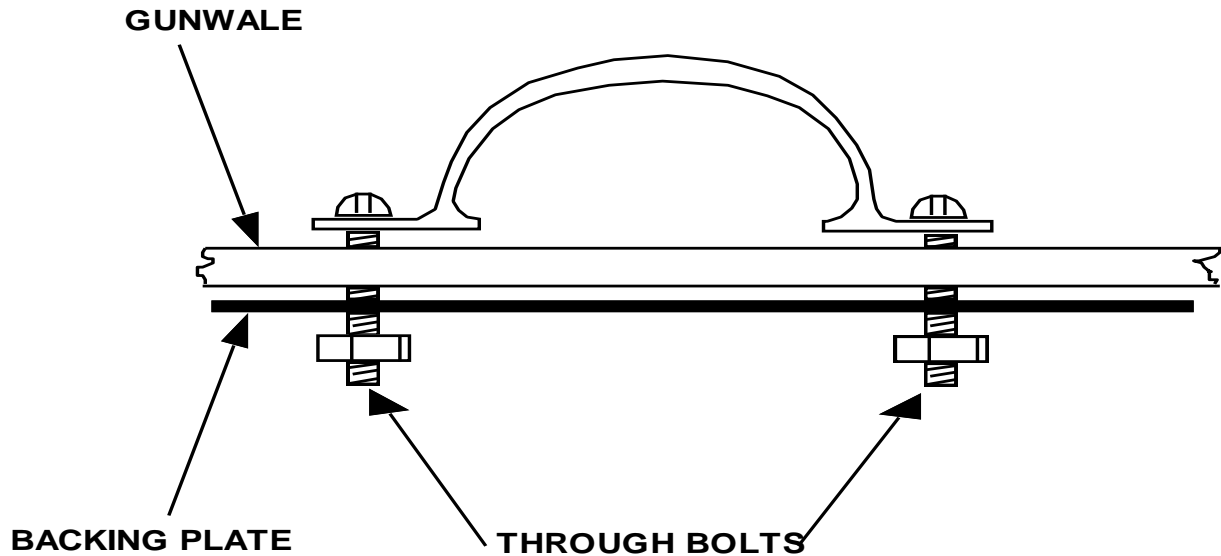

NOTE

No copper alloy (brass or bronze) handles or both should be used on aluminum boats because of the corrosive effects of the electrolyte.

BOLT ENDS

When the handles are installed on the boat, the ends of the through-bolts should not protrude more than 1/4" beyond the backing plates, particularly if the boat lacks a forward deck. Bolt ends which are too long might injure an occupant of the boat.

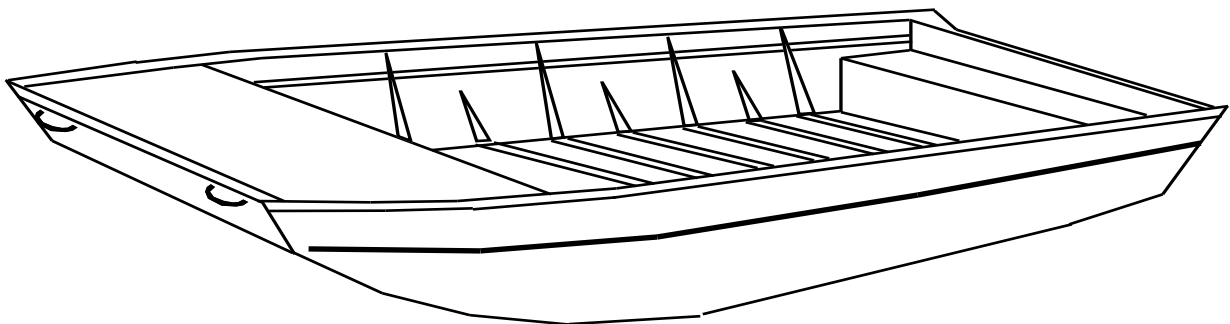

LOCATION

At least two handles should be installed on the boat (one on the port side and one on the starboard side) as far forward and as close to the gunwales as possible.

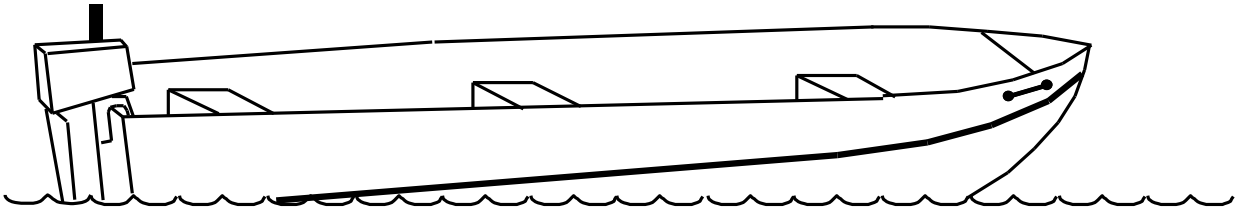

NOTE

IF BOAT REGISTRATION NUMBERS ARE IN THE DESIRED LOCATION FOR INSTALLATION OF THE HANDLES, THE NUMBERS CAN BE MOVED FARTHER AFT. FEDERAL REGISTRATION LAWS

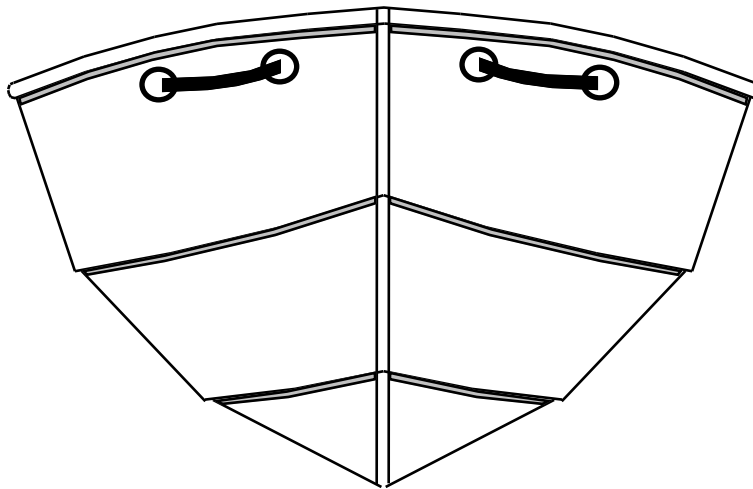

REMEMBER

IF YOU HAVE AN ACCIDENT, STAY WITH THE BOAT AND DON'T PANIC!

Handles installed in accordance with this guideline could save your life.

VESSEL NUMBERING AUTHORITIES

All undocumented vessels equipped with propulsion machinery must be registered in the State of principal use. A certificate of number will be issued upon registering the vessel. These numbers must be displayed on your vessel. The owner/operator of a vessel must carry a valid certificate of number whenever the vessel is in use. When moved to a new State of principal use, the certificate is valid for 60 days. Check with your State vessel numbering authority for numbering requirements. Some States require all vessels to be numbered. The Coast Guard issues the certificate of number in Alaska; all others are issued by the States or U.S. territories. In Alaska, application forms for Coast Guard registration numbers may be obtained through local post offices or any Coast Guard facility.

The following is a list of vessel numbering authorities:

Boat Registration Supervisor
Marine Police Division
Dept. of Conservation and Natural Resources
64 North Union St, Rm 756
Montgomery, AL 36130

Department of Public Safety
Pago Pago, AS 96799

Watercraft Registration Supervisor
Arizona Game and Fish Department
222 West Greenway Road
Phoenix, AZ 85023

Manager, Registration
Dept. of Finance and Administration
P.O. Box 1272 – Revenue Div.
Little Rock, AR 72203

Dept. of Motor Vehicles
2415 First Avenue
Sacramento, CA 95814-7291

Division of Parks and Outdoor Recreation
13787 South Highway 85
Littleton, CO 80125

Dept of Motor Vehicles
Marine Vessel Section
60 State Street
Wethersfield, CT 06109

Boat Registrations
Department of Natural Resources
and Environmental Control
Division of Fish and Wildlife
P.O. Box 1401
Dover, DE 19903

Metropolitan Police Dept.
Harbor Section
550 Water Street, S.W.
Washington, DC 20024

Department of Natural Resources
Division of Law Enforcement
3900 Commonwealth Blvd.
Mail Sta 660
Tallahassee, FL 32399-3000

Boating Registration Unit
2189 Northlake Parkway
Suite 108, Building 10
Tucker, GA 30084

Guam Boating Law Administrator
Harbor Unit, Guam Police Dept.
287 West O'Brien Drive
Agana, GM 96910

Department of Transportation
Harbors Division
79 South Nimitz Highway
Honolulu, HI 96813

Licensing Section
Dept. of Parks and Recreation
2177 Warm Springs Ave., Statehouse Mail
Boise, ID 83720

Department of Conservation
Division of Law Enforcement
524 South Second Street
Springfield, IL 62701-1787

Bureau of Motor Vehicles
Department of Natural Resources
IGCN, Room 409
100 N. Senate Ave
Indianapolis, IN 46204

Licensing Bureau
Dept. of Natural Resources
Fish and Wildlife Division
Wallace State Office Building
E. Ninth & Grand Avenue
Des Moines, IA 50319-0034

Licensing Division
Dept. of Wildlife and Parks
RR2, Box 54A
Pratt, KS 67124

Title Branch
Natural Resources and Environmental Cabinet
Kentucky Water Patrol
107 Mero Street

Motorboat Registration
Department of Wildlife and Fisheries
P.O. Box 14796
Baton Rouge, LA 70898-4796

Director, Licensing and Registration
Department of Inland Fisheries And Wildlife
284 State Street
Augusta, ME 04333

Licensing & Watercraft Registration Services
Tawes State Office Bldg. B-1
580 Taylor Avenue
Annapolis, MD 21401

Department of Fisheries, Wildlife and
Environmental Law Enforcement
Division of Law Enforcement
100 Nashua Street
Boston, MA 02114

Secretary of State
Information Services Division
7064 Crowner Drive
Lansing, MI 48918

License Bureau
Department of Natural Resources
500 Lafayette Road
St. Paul, MN 55155

Department of Wildlife, Fisheries & Parks
Post Office Box 451
Jackson, MS 39205

Motor Vehicle Bureau
Department of Revenue
Post Office Box 200
Jefferson City, MO 65105

Registrar's Bureau
Department of Justice
925 Main Street
Deer Lodge, MT 59722

Registration Supervisor
Nebraska Game & Parks Commission
Post Office Box 30370
Lincoln, NE 68503-0370

New Hampshire
Department of Safety
Division of Motor Vehicles
10 Hazen Drive
Concord, NH 03305

Division of Motor Vehicles
New Jersey State Police
Marine Law Enforcement Bureau
Post Office Box 7068
West Trenton, NJ 08628-0068

Motor Vehicles Department
Post Office Box 1028
Santa Fe, NM 87504-1028

Department of Motor Vehicles
Empire State Plaza
Swan Street Building
Albany, NY 12228

North Carolina
Wildlife Resources Commission
322 Chapanoke Road
Raleigh, NC 27603

Licensing Supervisor
State Game & Fish Department
100 North Bismarck Expressway
Bismarck, ND 58501-5095

Registration and Titling
Division of Watercraft
Ohio Dept. of Natural Resources
1952 Belcher Drive – C2
Columbus, OH 43224-1386

Oklahoma Tax Commission
409 NE 28th
Oklahoma City, OK 73105

Registration Manager
State Marine Board
435 Commercial Street, NE
Salem, OR 97310

Boat Registration
PO Box 1852
Harrisburg, PA 17105-1852

Director,
Numbering & Registration
Department of Natural Resources
Post Office Box 5887
Pureta De Tierra, PR 00906

Licensing Unit
Division of Business Affairs
Department of Environmental
Management
83 Park Street
Providence, RI 02903

Titling & Registration
Wildlife & Marine Resources
Post Office Box 167
Columbia, SC 29202

Department of Motor Vehicles
Public Safety Building
118 W. Capitol Avenue
Pierre, SD 57501-2017

Boat Registration
Tennessee Wildlife Resource Agency
Post Office Box 40747
Nashville, TN 37204

Texas Parks and Wildlife Dept.
4200 Smith School Road
Austin, TX 78744

Boating Law Administrator
Department of Planning & National Resources
231 Nisky Center
St. Thomas, USVI 00802

Tax Commission
Motor Vehicle Division
1095 Motor Avenue
Salt Lake City, UT 84116

Department of Motor Vehicles
Vermont State Police
Marine Division
103 South Main Street
Waterbury, VT 05676

Boating Law Administrator
Dept of Game and Inland Fisheries
Post Office Box 11104
4010 W Broad Street
Richmond, VA 23230-1104

Titling and Registration Service
Department of Licensing
Highway Licenses Bldg PB-01
Olympia, WA 98504

Division of Motor Vehicles
Department of Natural Resources
State Office Building
1800 East Washington Street
Charleston, WV 25305

Department of Natural Resources
Post Office Box 7924
124 S Webster Street
Madison, WI 53707

Boating Law Administrator
Wyoming Game and Fish Department
5400 Bishop Boulevard
Cheyenne, WY 82006

Department of Public Safety
Civic Center
Saipan, CNMI 96950

COAST GUARD DISTRICT OFFICES

Commander (b)
First Coast Guard District
408 Atlantic Ave.
Boston, MA 02210-2209

Commander (b)
Second Coast Guard District
1222 Spruce Street
St. Louis, MO 63101-2832

Commander (b)
Fifth Coast Guard District
431 Crawford Street
Portsmouth, VA 23704-5004

Commander (b)

909 SE 1st Ave
Miami, FL 33130-1608

Commander (b)
Eighth Coast Guard District
501 Magazine Street
New Orleans, LA 70130-3396

Commander (b)
Ninth Coast Guard District
1240 E. 9th Street
Cleveland, OH 44199-2060

Commander (b)
Eleventh Coast Guard District
400 Oceangate Blvd.
Long Beach, CA 90882-5399

Commander (b)
Thirteenth Coast Guard District
915 2nd Ave
Seattle, WA 98174-1067

Commander (b)

Honolulu, HI 96850-4982

Commander (b)
Seventeenth Coast Guard District
P.O. Box 3-5000
Juneau, AK 99802-1217