



COMMITTEE DRAFT ISO/CD 13297	
Date 2007-02-23	Reference number <b>ISO/TC 188 / SC</b> N 863
Supersedes document	

**WARNING:** This document is not an International Standard. It is distributed for review and comment. It is subject to change without notice and may not be referred to as an International Standard.

<b>ISO/TC 188 / SC</b>
Title <b>Small craft</b>
Secretariat <b>SIS, Sweden</b>

Circulated to P- and O-members, and to technical committees and organizations in liaison for:
<input type="checkbox"/> discussion at _____ on _____ [venue/date of meeting]
<input checked="" type="checkbox"/> comments by <b>2007-05-23</b> [date]
<input type="checkbox"/> approval for registration as a DIS in accordance with 2.5.6 of part 1 of the ISO/IEC Directives, by _____ [date]
(P-members vote only: ballot form attached)
<b>P-members of the technical committee or subcommittee concerned have an obligation to vote.</b>

*English title*

**Small craft – Electrical systems – Alternating current installations**

*French title*

**Petits navires – Systèmes électriques – Installations de distribution de courant alternatif**

Reference language version:  English  French  Russian

Introductory note

Reference number of working document: **ISO/TC 188 N 863**

Date: 2007-02-22

Reference number of document: **ISO/CD 13297**

Committee identification: ISO/TC 188/WG 10

Secretariat: SIS

## **Small craft — Electrical systems — Alternating current installations**

*Petits navires — Systèmes électriques — Installations de distribution de courant alternatif*

### **Warning**

This document is not an ISO International Standard. It is distributed for review and comment. It is subject to change without notice and may not be referred to as an International Standard.

Recipients of this draft are invited to submit, with their comments, notification of any relevant patent rights of which they are aware and to provide supporting documentation.

Document type: International standard  
Document subtype: if applicable  
Document stage: (30) Committee  
Document language: E

### Copyright notice

This ISO document is a working draft or committee draft and is copyright-protected by ISO. While the reproduction of working drafts or committee drafts in any form for use by participants in the ISO standards development process is permitted without prior permission from ISO, neither this document nor any extract from it may be reproduced, stored or transmitted in any form for any other purpose without prior written permission from ISO.

Requests for permission to reproduce this document for the purpose of selling it should be addressed as shown below or to ISO's member body in the country of the requester:

*[Indicate :  
the full address  
telephone number  
fax number  
telex number  
and electronic mail address*

*as appropriate, of the Copyright Manager of the ISO member body responsible for the secretariat of the TC or SC within the framework of which the draft has been prepared]*

Reproduction for sales purposes may be subject to royalty payments or a licensing agreement.

Violators may be prosecuted.

## Contents

Page

Foreword .....	iv
1 Scope .....	1
2 Normative references .....	1
3 Terms and definitions .....	1
4 General requirements .....	4
5 Marking .....	5
6 Ignition sources .....	6
7 Overcurrent protection .....	7
8 Ground fault protection/earth leakage protection .....	8
9 Appliances and equipment .....	8
10 System wiring .....	8
11 Installation .....	9
12 Panel boards (switchboards) .....	11
13 Socket outlets .....	11
14 Power source options .....	12
15 Inverters and inverterchargers .....	12
Annex A (normative) Conductor requirements .....	15
Annex B (normative) Instructions to be included with owner's manual (ISO 10240) .....	16
Annex C (informative) Recommended system tests .....	17
Annex D (informative) Related standards and brief description of their contents .....	18
Annex E (informative) Typical a.c. system installation diagrams .....	20
Annex F (informative) Typical battery charger/inverter installation diagrams .....	24

## Foreword

ISO (the International Organization for Standardization) is a worldwide federation of national standards bodies (ISO member bodies). The work of preparing International Standards is normally carried out through ISO technical committees. Each member body interested in a subject for which a technical committee has been established has the right to be represented on that committee. International organizations, governmental and non-governmental, in liaison with ISO, also take part in the work. ISO collaborates closely with the International Electrotechnical Commission (IEC) on all matters of electrotechnical standardization.

International Standards are drafted in accordance with the rules given in the ISO/IEC Directives, Part 2.

The main task of technical committees is to prepare International Standards. Draft International Standards adopted by the technical committees are circulated to the member bodies for voting. Publication as an International Standard requires approval by at least 75 % of the member bodies casting a vote.

Attention is drawn to the possibility that some of the elements of this document may be the subject of patent rights. ISO shall not be held responsible for identifying any or all such patent rights.

ISO 13297 was prepared by Technical Committee ISO/TC 188, *Small craft*.

This second edition cancels and replaces the first edition (ISO 13297:2000), which has been technically revised.

# Small craft — Electrical systems — Alternating current installations

## 1 Scope

This International Standard establishes the requirements for the design, construction and installation of low-voltage alternating current electrical systems which operate at nominal voltages less than 250 V on small craft up to 24 m length of hull.

## 2 Normative references

The following referenced documents are indispensable for the application of this document. For dated references, only the edition cited applies. For undated references, the latest edition of the referenced document (including any amendments) applies.

ISO 8846, *Small craft — Electrical devices — Protection against ignition of surrounding flammable gases*

ISO 9094-1:—<sup>1)</sup>, *Small craft — Fire protection — Part 1: Craft with a hull length of up to and including 15 m*

ISO 10133:—<sup>2)</sup>, *Small craft — Electrical systems — Extra low voltage d.c. installations*

ISO 10240, *Small craft — Owner's manual*

IEC 60079-0, *Electrical apparatus for explosive gas atmospheres — Part 0: General requirements*

IEC 60446, *Basic and safety principles for non-machine interface marking and identification — Identification of conductors by colours or numerals.*

IEC 60529:1989, *Degrees of protection provided by enclosures (IP code)*

IEC 60947-7-1, *Low-voltage switchgear and control gear — Part 7: Ancillary equipment; Section one: Terminal blocks for copper conductors*

## 3 Terms and definitions

For the purposes of this document, the following terms and definitions apply.

### 3.1

#### craft's ground

#### craft's earth

ground (earth) which is established by a conducting connection (intended or accidental) with the common ground/earth (potential of the earth's surface), including any conductive part of the wetted surface of the hull

---

<sup>1)</sup> To be published. (Revision of ISO 9094-1:2003)

<sup>2)</sup> To be published. (Revision of ISO 10133:2000)

**3.2**  
**residual (differential) current device), RCD**  
**ground fault circuit interrupter, GFCI**

electro mechanical switching device or association of devices designed to make, carry and break currents under normal service conditions and to cause the opening of contacts when the residual current attains a given value under specified conditions

NOTE RCD/GFCI serve to reduce the risk of injury to people from electrical shock hazard.

**3.3**  
**polarization transformer**

transformer which automatically orientates the neutral and live conductors in the system in the same polarity orientation as the polarized system of the craft

**3.4**  
**isolation transformer**

transformer with protective separation between the input and output windings and the protective conductor

**3.5**  
**neutral conductor**

conductor connected to the neutral point of a system and capable of contributing to the transmission of electrical energy

**3.6**  
**protective earthing conductor**  
**protective grounding conductor**

conductor, not normally carrying current, used for some measure of protection against electric shock, for electrically connecting any of the following parts of electrical equipment to the craft's ground/earth and to the shore a.c. grounding conductor through the shore power cable

- a) Exposed conductive parts of electrical equipment
- b) Extraneous conductive parts
- c) The main grounding (earthing ) terminal
- d) Earth electrode(s)
- e) The earth point of a source, or an artificial neutral

**3.7**  
**live conductor**

conductor or conductive part intended to be energized in normal use, including a neutral conductor

**3.8**  
**ignition-protected**

equipment designed and constructed to comply with ISO 8846

NOTE Examples of devices are circuit breakers, fuses, switches, instruments and indicators.

**3.9**  
**overcurrent protection device**

device, such as a fuse or circuit breaker, designed to interrupt the circuit when the current flow exceeds a predetermined value for a predetermined time

**3.10**  
**panel board (switchboard)**

assembly of devices, such as circuit breakers, fuses, switches, instruments and indicators, for the purpose of controlling and/or distributing electrical power

**3.11****polarized system**

system in which the neutral and live conductors are connected in the same relation to all terminals on devices or receptacles (socket outlets) in a circuit

**3.12****shore-power inlet**

fitting designed for mounting on a craft, of a shrouded male type, to connect to the female connector on the craft end of the shore-power cable in order to make the electrical connection for transmission of electrical energy

**3.13****trip free circuit breaker:**

mechanical switching device capable of making, carrying and breaking currents under normal circuit conditions and also making, carrying for a specified time and breaking currents under specified abnormal circuit conditions such as those of overload or short circuit, and which are designed so that the resetting means cannot be manually held in place to override the current-interrupting mechanism

**3.14****accessible**

capable of being reached for inspection, removal or maintenance without removal of permanent structure of the craft

**3.15****readily accessible**

capable of being reached quickly and safely for effective use without the use of tools

**3.16****sheath**

uniform and continuous protective tubular covering of metallic or non-metallic material, such as moulded rubber, moulded plastic, woven sleeving or flexible tubing, around one or more insulated conductors

EXAMPLE Rubber, moulded plastic, woven sleeving or flexible tubing.

**3.17****conduit**

part of a closed wiring system of circular or non-circular cross section for insulated conductors and/or cables in electrical installations, allowing them to be drawn in and/or replaced

**3.18****cable trunking**

system of closed enclosures comprising a base with a removable cover intended for the complete surrounding of insulated conductors, cables, cords and for the accommodation of other electrical equipment

**3.19****double-pole circuit breaker**

device intended to interrupt both the neutral and live conductors in a circuit simultaneously when a designated current is exceeded for a predetermined time

**3.20****captive spade terminal**

conductor terminal component which is maintained in the connection to the screw or stud even when the threaded terminal fastener is loose

**3.21****exposed conductive part**

conductive part of electrical equipment, which can be readily touched and which is not normally live, but which may become live under fault conditions

**3.22**

**fuse**

device that by fusing of one or more of its specifically designed and proportioned components, opens a circuit in which it is inserted by breaking the current when this exceeds a given value for a sufficient time

NOTE The fuse comprises all the parts that form the complete device.

**3.23**

**galvanic isolator**

device installed in series with the a.c. protective conductor of the shore power cable to block low voltage d.c. galvanic current flow, but permit the passage of alternating current (a.c.) normally associated with the protective conductor

**3.24**

**inverter**

device powered by batteries, designed primarily to provide a.c. at a required voltage and frequency

**3.25**

**inverter/charger**

device designed to supply either a.c. power to a craft's electrical system or to utilize the craft's a.c. electrical distribution system to charge or maintain a battery or batteries supplying direct current (d.c.)

## **4 General requirements**

**4.1** The protective conductor insulation shall be green or green with yellow stripe. Neither colour shall be used for current carrying conductors.

NOTE The equipotential bonding conductor of the d.c. electrical system, see ISO 10133, also uses green or green with yellow stripe insulation and is connected to various exposed conductive parts of direct current electrical devices, other extraneous conductive parts and the d.c. negative ground/earth.

**4.2** The protective conductor shall be connected to the craft's d.c. negative ground/earth as close as practicable to the battery (d.c.) negative terminal.

NOTE If an RCD (whole craft residual current device) or an isolation transformer is installed in the main supply circuit of the a.c. system (8.2), the negative ground terminal of the d.c. system need not be connected to the the a.c. shore ground (protective conductor).

**4.3** For craft with fully insulated d.c. systems, see ISO 10133, the a.c. protective conductor shall be connected to the hull of a metallic hull craft, the craft external ground/earth or the craft lightning ground plate, if fitted.

**4.4** Metallic craft hulls shall not be used as a conductor.

**4.5** The protective conductor shall be connected to metallic hulls at a location above any anticipated water accumulation.

**4.6** Individual circuits shall not be capable of being energized by more than one source of electrical power at a time. Each shore-power inlet, generator or inverter is a separate source of electrical power. The transfer from one power source circuit to another shall be made by a means which opens all current carrying conductors, live and neutral, before closing the alternate source circuit, prevents arc-over between contacts and is interlocked by mechanical or electromechanical means. Both current carrying conductors, live and neutral, shall be broken simultaneously when changing power sources.

EXCEPTION Devices installed in accordance with the manufacturer's instructions that are designed to synchronize multiple power sources of different origins

**4.7** Energized parts of electrical equipment shall be guarded against accidental contact by the use of enclosures of at least IEC 60529-IP 2X or other protective means which shall not be used for non-electrical

equipment. Access to energized parts of the electrical system shall require the use of hand tools or be at least IP 2X, unless otherwise specified. A suitable warning sign shall be displayed (see 5.2).

**4.8** The neutral conductor shall be grounded (earthed) only at the source of power, i.e. at the onboard generator, the secondary of the isolation or polarization transformer, or the shore-power connection. The shore power neutral shall be grounded through the shore power cable and shall not be grounded on board the craft.

**4.9** A galvanic isolator or other suitable device may be fitted in the protective conductor to resist imported stray galvanic current flow while permitting the passage of a.c. current, if present. Galvanic isolators shall be designed to withstand the application of power from a short circuit test from a source capable of delivering 5000 A r.m.s. symmetrically to its output test terminals for the time required for the circuit breaker in the test circuit to trip. After three applications of the short-circuit test the electrical and mechanical characteristics of the isolator shall be unchanged.



**4.10** Reverse polarity indicating devices providing a continuous visible or audible signal shall be installed in shore power systems and must respond to the reversal of the ungrounded (black) and the grounded (white or light blue) conductors (see Annex C, Figure 2) if the polarity of the system must be maintained for the proper operation of the electrical devices in the system, or a branch circuit is provided with overcurrent protection in only the ungrounded current carrying conductors.

NOTE 1 Reverse polarity indicating devices respond to the reversal of an ungrounded conductor grounded (white or light blue) conductor only when there is continuity of the protective grounding (green or green with yellow stripe) conductor to shore.

NOTE 2 Reverse polarity indicating devices might not respond to reversals of an ungrounded conductor and the protective grounding conductor, the grounded (white or light blue) conductor and the protective grounding conductor, or three-phase conductors.

NOTE 3 Reverse polarity indicating devices are not required in systems employing polarization or isolation transformers that establish polarity on the craft.

## 5 Marking

**5.1** Shore-power inlets shall be marked to indicate voltage, current, shock hazard symbol  and read owner's manual symbol .

**5.2** A permanently mounted waterproof warning sign shall be located at the panel board on the craft. The sign shall include the information shown in Figure 1a) or 1b).

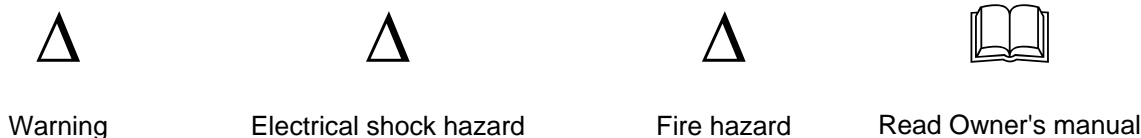

### a) Suggested warning sign using symbols

**WARNING — To minimize shock and fire hazards:**

- 1 Turn off craft's shore-power connection switch before connecting or disconnecting shore-power cable.**
- 2 Connect shore-power cable to craft's inlet before connecting to shore-power source.**

- |   |
|---|
| <p>3 If incorrect polarity is indicated, immediately disconnect cable.</p> <p>4 Disconnect shore-power cable at shore-power source first.</p> <p>5 Close shore-power inlet cover tightly.</p> |
| <p><b>DO NOT ALTER SHORE-POWER CABLE CONNECTORS.</b></p>  |

NOTE 1 Item 3 is required only if a polarity indicator is installed in the system.

NOTE 2 Items 2, 4 and 5 are not required for permanently connected shore power cable installations.

**b) Suggested warning sign with text in language appropriate to the country of use**

**Figure 1 — Suggested warning signs**

**5.3** Switches and controls shall be marked to indicate their function, unless the purpose of the switch is obvious and if operation of the switch could not, under normal operating conditions, cause a hazardous condition.

**5.4** Electrical equipment shall be marked or identified to indicate:

- a) manufacturer's identification;
- b) model number or designation;
- c) electrical rating in volts and amperes or volts and watts;
- d) phase and frequency, if applicable;
- e) ignition protected, if applicable, by ISO 8846.

**6 Ignition sources**

Electrical components installed in compartments which in normal operation may contain LPG gases or petrol vapour e.g. petrol tank, engine compartment and LPG lockers, shall be designed to be compliant with ISO 8846 or designed to IEC 60079-0, and shall be located in accordance with ISO 9094-1.

## 7 Overcurrent protection

### 7.1 General requirements

**7.1.1** In unpolarized systems double-pole circuit breakers opening both live and neutral conductors are required.

**7.1.2** Fuses shall not be installed in unpolarized systems.

**7.1.3** Overcurrent protection devices for motor loads shall have a predetermined value of current flow consistent with demand load characteristics of the protected circuit.

**7.1.4** All a.c. motor installations and each motor of a motor-operated device shall be individually protected in accordance with 7.1.3 or by an integral overcurrent or thermal protection device.

An exception may be made for motors that will not overheat under continuous locked rotor conditions.

**7.1.5** The rating of the overcurrent protection device shall not exceed the maximum current-carrying capacity of the conductor being protected. See Table A.1.

### 7.2 Main supply circuits

**7.2.1** Double pole circuit breakers shall be installed in conductors to the shore power supply circuits.

**7.2.2** A manually reset trip-free circuit breaker shall be installed within 0,5 m of the source of power or, if impractical, the conductor from the source of power to the panelboard circuit breaker shall be contained within a protective covering, such as a junction box, control box, enclosed panel board or within conduit or cable trunking or equivalent protective covering. If the location of the main shore power inlet circuit breaker exceeds 3 m from the shore power inlet connection or the electrical attachment point of a permanently installed shore power cord, additional fuses or circuit breakers shall be provided within 3 m of the inlet or attachment point to the electrical system in the craft, measured along the conductor.

**7.2.3** Overcurrent protection shall be provided for isolation and polarization transformers, including a bank of transformers operating as a unit. Each transformer shall be protected by an individual overcurrent device on the primary side, rated at not more than 125 % of the rated primary current of the transformer.

### 7.3 Branch circuits

**7.3.1** The live conductor of each branch circuit in a polarized system shall be provided with overcurrent protection, i.e. fuse or circuit breaker, at the point of connection to the main panel board bus.

**7.3.2** Both conductors of each branch circuit in unpolarized systems shall be provided with overcurrent protection by double-pole circuit breakers and double pole switches, if used, at the point of connection to the main panel board bus.

**7.3.3** Simultaneous trip-circuit breakers shall be provided in power-feeder conductors as follows:

- a) 120 volt a.c. single phase - ungrounded (neutral) and grounded (live) conductors
- b) 240volt a.c. - both ungrounded conductors
- c) 120/240 volt a.c single phase - both ungrounded conductors
- d) 120/240 volt a.c. delta three-phase - all ungrounded conductors
- e) 120/208 volt a.c. wye three-phase - all ungrounded conductors

- f) 240 volt a.c. three-phase - all ungrounded conductors

## 8 Ground fault protection/earth leakage protection

8.1 GFCIs (RCDs) shall be of the trip-free type.

8.2 The craft shall be provided with earth leakage protection in the main supply circuit by:

- a) a double pole RCD having a maximum nominal trip sensitivity of 30 mA and 100 ms maximum trip time located in accordance with 7.2.2, or:
- b) each socket outlet located in galley, toilet, machinery space or weather deck shall be protected by a GFCI (RCD) having a maximum sensitivity of 10 mA.

8.3 The GFCI (RCD) device shall have an internal circuit for manual testing of trip function.

NOTE GFCI(RCD) double pole receptacle (socket outlet) devices may be installed as part of a convenience outlet installation, either in single-outlet applications or in multiple "feed through" installations, i.e. series of socket outlets connected in parallel such that the first GFCI (RCD) protects everything in the circuit.

## 9 Appliances and equipment

9.1 Appliances and fixed a.c. electrical equipment installed on a craft shall have exposed conductive parts connected to the protective conductor, unless the appliance is of double-insulated construction.

9.2 Integral or external overcurrent protection shall be provided.

## 10 System wiring

10.1 Conductors shall have a minimum rating of 300/500 V. Flexible cords shall have a minimum rating of 300/300 V.

10.2 Conductors and flexible cords shall be of solid or multistrand copper, and of sizes no smaller than those determined by reference to Table A.1.

10.2.1 Solid conductors, if used, shall be run in rigid conduit or cable trunking throughout the entire length and terminated in a junction box at each end. The solid conductor shall not extend outside the junction box.

10.2.2 Solid conductors shall not be less than 2,5 mm<sup>2</sup> cross sectional area and comply with IEC 60228, Conductors of insulated cables.

NOTE 1 A conductor used for equipment grounding is not considered a current carrying conductor when referencing Table A.1

NOTE 2 The use of solid conductors is not recommended on installations that are subject to vibration.

10.3 The insulation temperature rating of conductors and flexible cords outside engine spaces shall be at least 60 °C.

10.4 Conductors shall be at least 1 mm<sup>2</sup> in area.

An exception may be made for conductors of minimum 0,75 mm<sup>2</sup> area which may be used as internal wiring in panel boards.

**10.5** Conductor insulation temperature rating in engine spaces shall be 70 °C minimum, the conductor shall be oil resistant, or shall be protected by insulating conduit or sleeving, and shall be derated in allowable current-carrying capacity in accordance with Annex A.

**10.6** The protective conductor shall have a cross-sectional area equal to that of the main conductors,

- a) if the latter is than 16 mm<sup>2</sup> cross sectional area, subject to a minimum of 1,5 mm<sup>2</sup>, or
- b) a cross sectional area not less than 50 % of the main conductor if the latter is more than 16 mm<sup>2</sup> cross sectional area, subject to a minimum of 16 mm<sup>2</sup>.

**10.7** Live, neutral and protective conductors of the a.c. system shall be identified. Identification may be made by insulation colour, by numbering or other means, on the wiring diagram for the system supplied with the craft. Insulation colours used, shall be in conformance with IEC 60446:

- Live conductors: black or brown
- Neutral conductors: white or light blue
- Protective conductors: green or green with yellow stripe (see 4.1)

NOTE A colour stripe may be added to live and neutral conductor insulation for identification in the system.

Yellow, green or green with yellow stripe insulation colour shall not be used for live or neutral conductors of the a.c. system.

## 11 Installation

**11.1** Conductor connections shall be in locations protected from the weather or in enclosures in accordance with IEC 60529-IP 55 as a minimum. Connections above deck exposed to intermittent immersion shall be in IEC 60529-IP 67 enclosures as a minimum.

**11.2** Conductors shall be supported throughout their length in conduits, cable trunking or trays, or by individual supports at maximum intervals of 450 mm.

**11.3** An a.c. circuit shall not be contained in the same wiring system as a d.c. circuit, unless one of the following methods of separation is used:

- a) For a multicore cable or cord, the cores of the a.c. circuit are separated from the cores of the d.c. circuit by an earthed metal screen of equivalent current carrying capacity to that of the largest core of the a.c. circuit;
- b) the cables are insulated for their system voltage and installed in a separate compartment of a cable ducting or trunking system;
- c) the cables are installed on a tray or ladder where physical separation is provided by a partition;
- d) a separate conduit, sheathing or trunking system is used;
- e) the a.c and d.c. conductors are fixed directly to a surface and separated by at least 100 mm.

**11.4** Current carrying conductors of the a.c. system shall be routed above foreseeable levels of bilgewater and in other areas where water may accumulate, or at least 25 mm above the water level at which the automatic bilge pump switch activates.

If conductors must be routed in the bilge area, the wiring and connections shall be in enclosures in accordance with IEC 60529-IP 67, such as continuous conduit, as a minimum, and there shall be no connections below the foreseeable water level.

**11.5** Metals used for terminal studs, nuts and washers shall be corrosion-resistant and galvanically compatible with the conductor and terminal. Aluminum and unplated steel shall not be used for studs, nuts or washers in electrical circuits.

**11.6** Solderless crimp-on terminals and connectors shall only be used on stranded conductors and connectors shall be attached with the type of crimping tool designed for the termination used and for producing a connection meeting the requirements of 11.13.

**11.7** All stranded conductors shall have suitable terminals installed, i.e. no bare wires to stud or screw connections.

**11.8** All solid conductors shall terminate with a stud or screw connection, i.e. bus bar or terminal strip.

NOTE Means should be provided to ensure that the screw cannot loosen over time by vibration.

**11.9** Screw-clamp or screwless terminals shall conform to IEC 60947-7-1. Other terminals shall be of the ring or captive spade type not dependent on screw or nut tightness alone for retention on the screw or stud. Captive spade terminals shall be of the self locking type.

Exception: friction type connectors on stranded conductors may be used in circuits not exceeding 20 A if the connection does not separate when subjected to a force of 20 N.

**11.10** Twist-on connectors (wire nuts) shall not be used.

**11.11** Exposed shanks of terminals shall be protected against accidental shorting by insulating barriers or sleeves, except those in the protective conductor system.

**11.12** Conductors shall be routed away from exhaust pipes and other heat sources which can damage the insulation. The minimum clearance is 50 mm from water cooled exhaust components and 250 mm from dry exhaust components, unless an equivalent thermal barrier is provided.

**11.13** Conductors which may be exposed to physical damage shall be protected by sheaths, conduits or other equivalent means. Conductors passing through bulkheads or structural members shall be protected against insulation damage by chafing.

**11.14** Each conductor-to-connector and conductor-to-terminal connection shall be capable of withstanding a tensile force equal to at least the value shown in Table 1 for the smallest conductor in the connection for 1 min, without separating.

**Table 1 — Tensile values for connectors**

Conductor size mm <sup>2</sup>	Tensile force N	Conductor size mm <sup>2</sup>	Tensile force N	Conductor size mm <sup>2</sup>	Tensile force N
0,75	40	6	200	50	400
1	60	10	220	70	440
1,5	130	16	260	95	550
2,5	150	25	310	120	660
4	170	35	350	150	770

**11.15** No more than four conductor connectors shall be secured to one terminal stud.

## 12 Panel boards (switchboards)

**12.1** An a.c. system panel board with a lamp indicating system on/off function shall be installed.

**12.2** A system voltmeter shall be installed on the panel board if the system is designed to supply motor circuits or if an onboard generator is installed.

**12.3** Panel boards shall be permanently marked with the system voltage, example: 230 V a.c. or 230 V 50 Hz.

**12.3.1** If the frequency is other than 50 hertz, the frequency shall be indicated.

**12.3.2** For three-phase systems the system voltage, phase and number of conductors shall be indicated.

**12.4** The front side of panel boards, i.e. the switch and circuit breaker operating face, shall be readily accessible, and the rear side, i.e. the terminal and connection side, accessible.

**12.5** Connections and components on panel boards shall be in locations protected from the weather in conformity with IEC 60529:

- IP 67 as a minimum, if exposed to short term immersion;
- IP 55 as a minimum, if exposed to splashing water;
- IP 20 as a minimum, if located in protected locations inside the craft.

**12.6** Craft equipped with both d.c. and a.c. electrical systems shall have their distribution from either separate panel boards or from a common one with a partition or other positive means provided to separate clearly the a.c. and d.c. sections from each other, and be clearly identified. Wiring diagrams to identify circuits, components and conductors shall be included with the craft.

## 13 Socket outlets

**13.1** Socket outlets and matching plugs used on a.c. systems shall not be interchangeable with those used in the d.c. system on the craft.

**13.2** Socket outlets installed in locations subject to rain, spray or splash shall be in enclosures conforming with IEC 60529-IP 55 as a minimum, when not in use. Socket outlets mated with the appropriate plug shall also remain sealed in accordance with IEC 60529.

**13.3** Socket outlets installed in areas subject to flooding or momentary submersion shall be in enclosures in accordance with IEC 60529-IP 67 as a minimum, also meeting these requirements when in use with electrical plugs.

**13.4** Socket outlets shall be of the earthing type with a terminal provided for the protective conductor.

**13.5** Socket outlets provided for the galley area shall be located so that appliance cords may be plugged in without crossing above a galley stove or sink or across a traffic area.

**13.6** Socket outlets shall have a voltage rating in accordance with the voltage supplied by the power sources.

**13.7** Shore power inlet sockets shall conform to IEC 60309-2 with a minimum rating of IP 44.

## 14 Power source options

14.1 Power for the a.c. system shall be supplied by one of the following means:

- a) single shore-power cable, power inlet, wiring and components with a capacity to supply the required design system load;
- b) multiple shore-power cables, power inlets, wiring and components with a capacity to supply the required design system load;
- c) inverter supplying a.c. power from the craft's d.c. system;
- d) on-board a.c. generator(s) supplying the required system load;
- e) combination of shore-power cable(s) and on-board generator(s) used simultaneously if the craft's circuitry is arranged such that the load connected to each source is isolated from the other or supplies are combined in accordance with 4.6.

14.2 The shore-power cable(s) alone or with on-board generator(s) capacity in addition shall be at least as large as the required system load(s).

14.3 A.c. generators where installed, shall be connected to the electrical distribution system as required in 4.6 or protected in accordance with 4.7.

14.4 The power feeder conductor from the a.c. generator shall be sized to transmit at least the generator's maximum rated output and shall be protected at the generator with over-current protection devices with a rating such that 120 % of the generator nominal output is not exceeded.

An exception may be made for self-limiting (self adjusting) generators whose maximum overload current does not exceed 120 % of its rated current output: these do not require additional external overcurrent protection.

See Annex D for examples of a.c. system diagrams.

## 15 Inverters and inverter/chargers

15.1 Inverters and inverter/chargers shall be non-rotating power inverters supplying less than 300 volts rms a.c. at a frequency of 50 or 60 hertz, and

15.1.1 be designed to operate up to an ambient temperature of 50 °C and withstand an ambient temperature of 70 °C without damage,

15.1.2 be automatically controlled,

15.1.3 provide isolation of the a.c. output from the d.c. supply circuit,

15.1.4 have controls which are readily accessible.

15.2 internal inverter socket outlets shall be protected by an internal GFCI (RCD) device. The socket outlets are to be used only with cord connected loads.

15.3 A visible means, i.e. voltmeter or lamp, indicating that the inverter is active on line and/or in standby mode, shall be provided at the a.c. panelboard; also a warning label to indicate that the electrical system includes an inverter. An example of such a sign:

### **⚠ WARNING - HIGH VOLTAGE**

— Craft is equipped with a d.c. to a.c. power inverter

- Avoid serious injury or death from electrical shock
- Disconnect a.c. shore power and d.c. battery power to inverter before opening panel or servicing electrical systems

**15.4** Inverters and inverter/chargers shall be permanently installed, fastened to permanent craft structure, and

- a) located in a ventilated, dry, readily accessible site where ambient temperatures will not exceed 50 °C,
- b) away from heat sources such as engine exhaust system components and other heat producing devices,
- c) mounted not less than 500 mm above normal accumulations of bilgewater.

**15.5** Inverters and inverter/chargers shall be ignition protected in accordance with ISO 8846 if installed in spaces containing petrol fueled engines or petrol fuel tanks and shall be so marked by the manufacturer, i.e. IGNITION PROTECTED ISO 8846.

**15.6** If a GFCI in the output of the inverter or inverter/charger the same requirements for ignition protection of the GFCI as 15.5 shall apply.

**15.7** Provision shall be made within the inverter or inverter/charger to permit the ready connection of the d.c. conductors.

**15.8** D. c. conductor terminals or conductors shall be labelled as follows:

- a) d.c.+, or POS, or +
- b) d.c.–, or NEG, or –

**15.9** The d.c. negative conductor between the engine negative terminal, or its bus, and the battery negative terminal shall be of a current carrying capacity at least equal to that of the inverter or inverter/charger positive conductor.

**15.10** A separate d.c. protective grounding conductor shall be connected from the metallic case or chassis of the inverter or inverter/charger to the engine negative terminal, or its bus, and be of a current carrying capacity equal to the d.c. positive conductor. This conductor shall not be connected to the d.c. negative at the inverter or inverter/charger.

**EXCEPTION** The d.c. protective grounding conductor may be one size smaller than the minimum size conductor required for the current carrying conductors providing the overcurrent protection device in the d.c. positive conductor is rated no greater than 135 % of the current carrying capacity of the protective grounding conductor and the conductor is no smaller than .75 mm<sup>2</sup> cross sectional area.

**15.11** Provision shall be made within the inverter or inverter/charger to permit the ready connection of three or more conductors with connectors meeting the requirements of 11.8 and 11.13. The terminals or conductors shall be labelled, e.g. L1, L2, G, N.

**15.12** A grounded neutral is required. The neutral for a.c. power sources shall be grounded only at the following points:

- a) the shore power neutral is grounded through the shore power cable and shall not be grounded on the craft;
- b) the inverter output neutral shall be grounded at the inverter;
- c) the inverter/ charger output neutral shall be grounded at the inverter/charger only when the device is the a.c. power source.

**EXCEPTION** On systems using an isolation transformer or a polarization transformer, the inverter or inverter/charger neutral and the transformer secondary neutral may be grounded at the main a.c. grounding bus instead of at the inverter or onverter/charger.

**15.13** If an inverter or inverter/charger and any other sources of a.c. can supply a branch circuit or socket outlet, the transfer from one power source circuit to another shall be made by a means that opens one source before closing the alternate source circuit, preventing the arc-over or feedback between sources.

**15.13.1** The transfer switch (e.g. switch gear) shall be protected against overcurrent.

**15.13.2** The current rating of the transfer switch shall be at least equivalent to the ampacity of the branch circuit feeding the transfer switch.

**15.14** Inverter or inverter/charger integral switching shall switch all ungrounded conductors and the grounded (neutral) conductor from ground.

**15.15** The a.c. protective grounding conductor shall be connected to the inverter or inverter/charger in a manner so that the a.c. groundconnection will not be disconnected in servicing. This conductor shall be in addition to and independant of the d.c. protective grounding conductor required.

**15.16** Access panels to compartments containing high voltage connections shall be provided with a label containing a warning about high voltage hazards, such as:

**△ WARNING - HIGH VOLTAGE**

- Avoid electrical shock hazard.
- Disconnect a.c. shore power and d.c battery power to inverter before opening panel

**15.17** All inverter/chargers shall include the following information for the charging system:

- a) input voltage, amperage and frequency;
- b) nominal output voltage and current;
- c) d.c. output voltage at float or shut off, if applicable;
- d) continuous output current at 12 volts (24 or 32) at specified input voltage at 25 °C;
- e) battery type.

**15.18** All inverters shall also include the following information:

- a) input voltage and amperage
- b) continuous output current at rated voltage
- c) nominal output voltage and frequency
- d) surge capability and duration

See Annex E for examples of inverter and inverter/charger installations.

## Annex A (normative)

### Conductor requirements

Table A.1 gives allowable continuous current ratings, in amperes, at different temperature ratings and the minimum number of strands for conductors. These values have been determined for an ambient temperature of 30 °C and apply to single conductors and stranding when no more than three conductors are bundled together.

For conductors in engine rooms (60 °C ambient) or when more than three conductors are bundled together, the maximum current rating in Table A.1 shall be derated by the factors below:

Temperature rating of conductor insulation:	Multiply maximum current from Table A.1 by:
70 °C	0,75
85 °C to 90 °C	0,82
105 °C	0,86
125 °C	0,89
200 °C	1

Number of conductors bundled:	Multiply maximum amperage from Table A.1 by:
4 to 6	0,7
7 to 24	0,6
25 or more	0,5

NOTE Derating reductions for temperature and bundling are cumulative.

**Table A.1 — Cross-sectional area conductor, allowable continuous current and stranding**

Cross-sectional area mm <sup>2</sup>	Maximum continuous current-carrying capacity, in amperes, for single conductors at insulation temperature ratings						Minimum number of strands	
	60 °C	70 °C	85 °C to 90 °C	105 °C	125 °C	200 °C	Type A	Type B
0,75	6	10	12	16	20	25	16	—
1	8	14	18	20	25	35	16	—
1,5	12	18	21	25	30	40	19	26
2,5	17	25	30	35	40	45	19	41
4	22	35	40	45	50	55	19	65
6	29	45	50	60	70	75	19	105
10	40	65	70	90	100	120	19	168
16	54	90	100	130	150	170	37	266
25	71	120	140	170	185	200	49	420
35	87	160	185	210	225	240	127	665
50	105	210	230	270	300	325	127	1 064
70	135	265	285	330	360	375	127	1 323
95	165	310	330	390	410	430	259	1 666
120	190	360	400	450	480	520	418	2 107
150	220	380	430	475	520	560	418	2 107

Conductors with Type B stranding shall be used for any wiring where frequent flexing is involved during use

Solid conductors shall not be less than 2,5 mm<sup>2</sup> cross sectional area (see 10.2.1).

NOTE Conductor current ratings may be interpolated for cross-sectional areas between those shown above.

## Annex B (normative)

### Instructions to be included with owner's manual (ISO 10240)

If an alternating current electrical system is installed in a craft, the owner's manual shall include instructions for the operation and maintenance of the system, including a wiring diagram with conductor identification, and at least the following.

- a) Do not modify the craft's electrical system or relevant drawings. Installation, alterations and maintenance should be performed by a competent marine electrical technician. Inspect system at least biennially.
- b) Disconnect shore power connections when system is not in use.
- c) Connect metallic housings or enclosures of installed electrical appliances to the protective conductor system in the craft (green or green with yellow stripe conductor).
- d) Use double insulated or grounded (earthed) electrical appliances.
- e) If reverse polarity indicator is activated, do not use electrical system. Correct polarity fault before activating the electrical system on the craft.<sup>3)</sup>
- f) **⚠ WARNING — Do not allow shore power cable end to hang in the water. An electrical field can be caused which can cause injury or death to nearby swimmers.**
- g) **⚠ WARNING — To minimize shock and fire hazards:**
  - Turn off craft's shore power connection switch before connecting or disconnecting shore-power cable.
  - Connect shore power cable to craft's inlet before connecting to shore power source.<sup>4)</sup>
  - Disconnect shore power cable at shore power source first.
  - If reverse polarity indicator is activated, disconnect cable immediately.<sup>5)</sup>
  - Close shore power inlet cover tightly.
- h) Do not alter shore-power cable connectors, use only compatible cable connectors and shore power receptacles.

---

<sup>3)</sup> Required for polarized systems with polarity indicator.

<sup>4)</sup> Not required for permanently connected shore-power cable installations.

<sup>5)</sup> Required only if reverse polarity indicator is required in the system.

## **Annex C** (informative)

### **Recommended system tests**

The following system tests should be performed upon completion of the a.c. installation:

- Residual current device (RCD) testing.
- Polarity test at distribution and at each outlet.

**CAUTION — Some electronic equipment may be damaged by high d.c. voltages.**

## Annex D (informative)

### Related standards and brief description of their contents

ISO 10088:<sup>6)</sup>, *Small craft — Permanently installed fuel systems and fixed fuel tanks*

Individual fuel tanks, 100 % pressure tested  
Non-metallic fuel tanks, fire tested  
Fire resistant flexible fuel hoses  
Fire test for non-metallic fuel system components  
Corrosion-resistant fuel tank materials  
Galvanically compatible metallic parts  
Anti siphon protection requirements  
Double clamping of fuel fill hoses  
Electrically ground major metallic parts  
100 % pressure test of entire fuel system

ISO 8846:1990, *Small craft — Electrical devices — Protection against ignition of surrounding flammable gases*

All components in petrol engines, petrol and LPG tank compartments to be ignition-protected to prevent open sparks. This applies to the entire engine, as well as all electrical contacts, commutators, brushes, collector rings, switches, relays, generators, fuses, distributors, engine-cranking motors, propulsion trim motors, etc.

The Standard further requires components to withstand any operating conditions of the device, including the maximum achievable overload up to 400 % of the rated current (circuit-breakers, switches and the like) and a stalled rotor condition for any motor with the circuit protected in an overcurrent protective device specified by the product manufacturer.

ISO 9097:1991, *Small craft — Electric fans*

ISO 8849:2002, *Small craft — Electrically operated bilge-pumps*

All components, if installed in a petrol engine, petrol or LPG tank compartment to be ignition-protected, have all wiring insulated, be suitable for marine environment, and not create a hazard when the motor is overloaded or stalled.

ISO 10133:<sup>7)</sup>, *Small craft — Electrical systems — Extra low voltage electrical installations*

All components fused  
All conductors insulated  
All electrical components installed in bilges or other compartments that may contain explosive gas are ignition protected  
Installation requirements for batteries and cables  
Requirements for ring or captive spade terminals on conductor connections.

---

<sup>6)</sup> To be published. (Revision of ISO 10088:2000)

<sup>7)</sup> To be published. (Revision of ISO 10133:2000)

ISO 10239:-<sup>8)</sup>, *Small craft — Liquefied petroleum gas (LPG) systems*

System to withstand temperature extremes  
 Appliances approved and installed only in ventilated compartments, tanks and pressure regulators in lockers identified and vented with overboard drains  
 Meet specifications for fuel lines and their supports  
 Appliance well secured with flame failure shutoff control device for each appliance  
 Warning labels on appliances  
 Pressure test on installed system  
 Any electrical device in lockers, designated for LPG storage, ignition-protected

ISO 9094-1:-<sup>9)</sup>, *Small craft — Fire protection — Part 1: Craft with a hull length of up to and including 15 m*

ISO 9094-2:-<sup>10)</sup>, *Small craft — Fire protection — Part 2: Craft with a hull length of over 15 m*

Specifications for exits and emergency exits  
 Material specifications in areas close to open flames  
 Self-extinguishing materials in engine compartment  
 Ventilation and flue protection for water heater  
 Sealed combustion systems on unattended appliances  
 Specification for fuel tanks  
 Requirement for portable fire-extinguishers, for accessibility, protection, stowage and locker identification size  
 Specification for number and types of fire-extinguishers  
 Specification for fixed fire-extinguishing system on some craft  
 Cylinder installation specification  
 Remote release for fixed systems  
 Distribution hoses and tubes fire-resistant  
 Specifications for discharge and control  
 Discharge and operating instructions

ISO 11105:1997, *Small craft — Ventilation of petrol engine and/or petrol tank compartments*

Ventilation amount based on compartment volume  
 Specification for compartment tightness  
 Natural and powered ventilation in engine compartments  
 Natural ventilation in certain fuel compartments  
 Ventilation openings on exterior of craft  
 Blower warning for craft operator

ISO 10134: 2003, *Small craft — Electrical devices — Lightning protection*

Requirements for design, construction and installation of lightning protection equipment, if fitted on small craft

IEC 60364-7-709:1994, *Electrical installations of buildings — Part 7: Requirements for special installations or locations — Section 709: Marinas and pleasure craft*

A.c. systems for marinas and connection to the craft

---

<sup>8)</sup> To be published. (Revision of ISO 10239:2000)

<sup>9)</sup> To be published. (Revision of ISO 9094-1:2003)

<sup>10)</sup> To be published. (Revision of ISO 9094-2:2002)

## Annex E (informative)

### Typical a.c. system installation diagrams

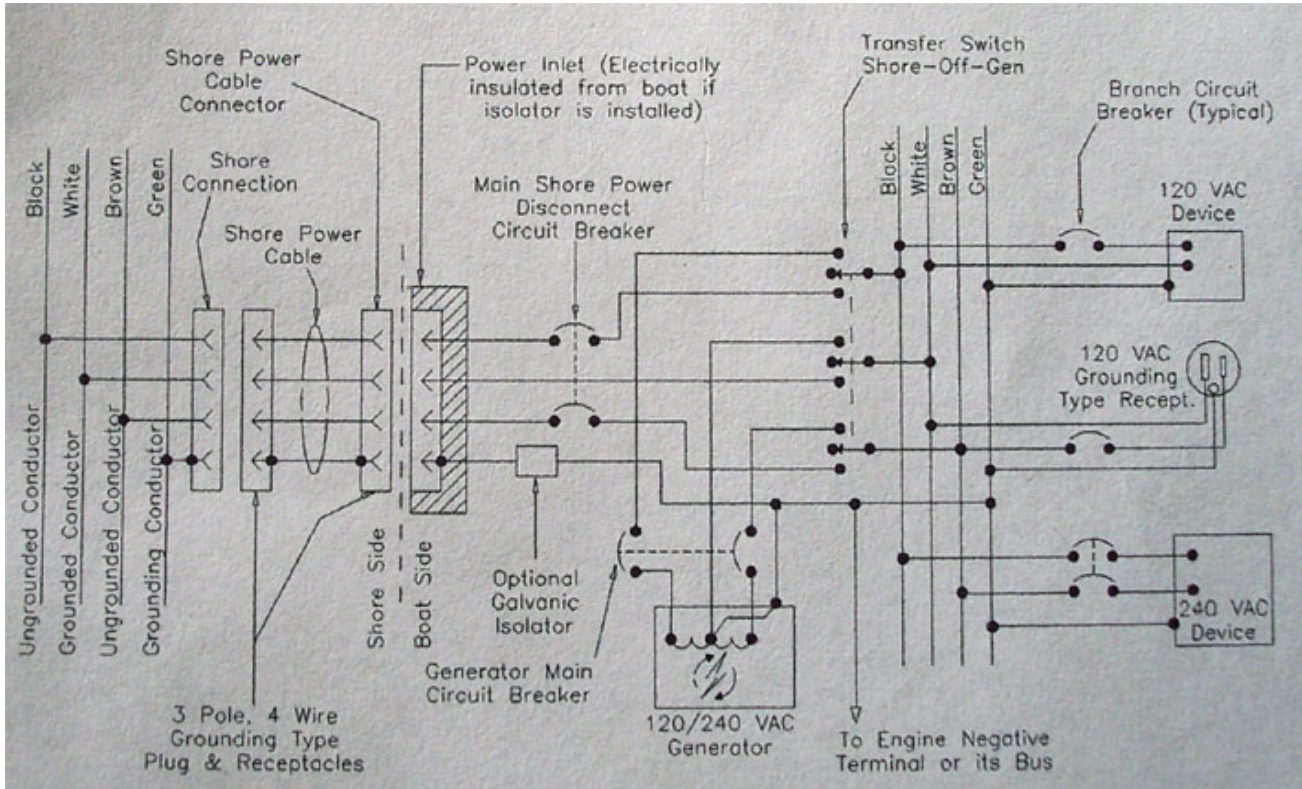

NOTE This diagram does not illustrate a complete system. Refer to the appropriate text.

**Figure E.1 — Single phase 120/240 Volt system with shore grounded (white) neutral conductor and grounding (green) conductor**

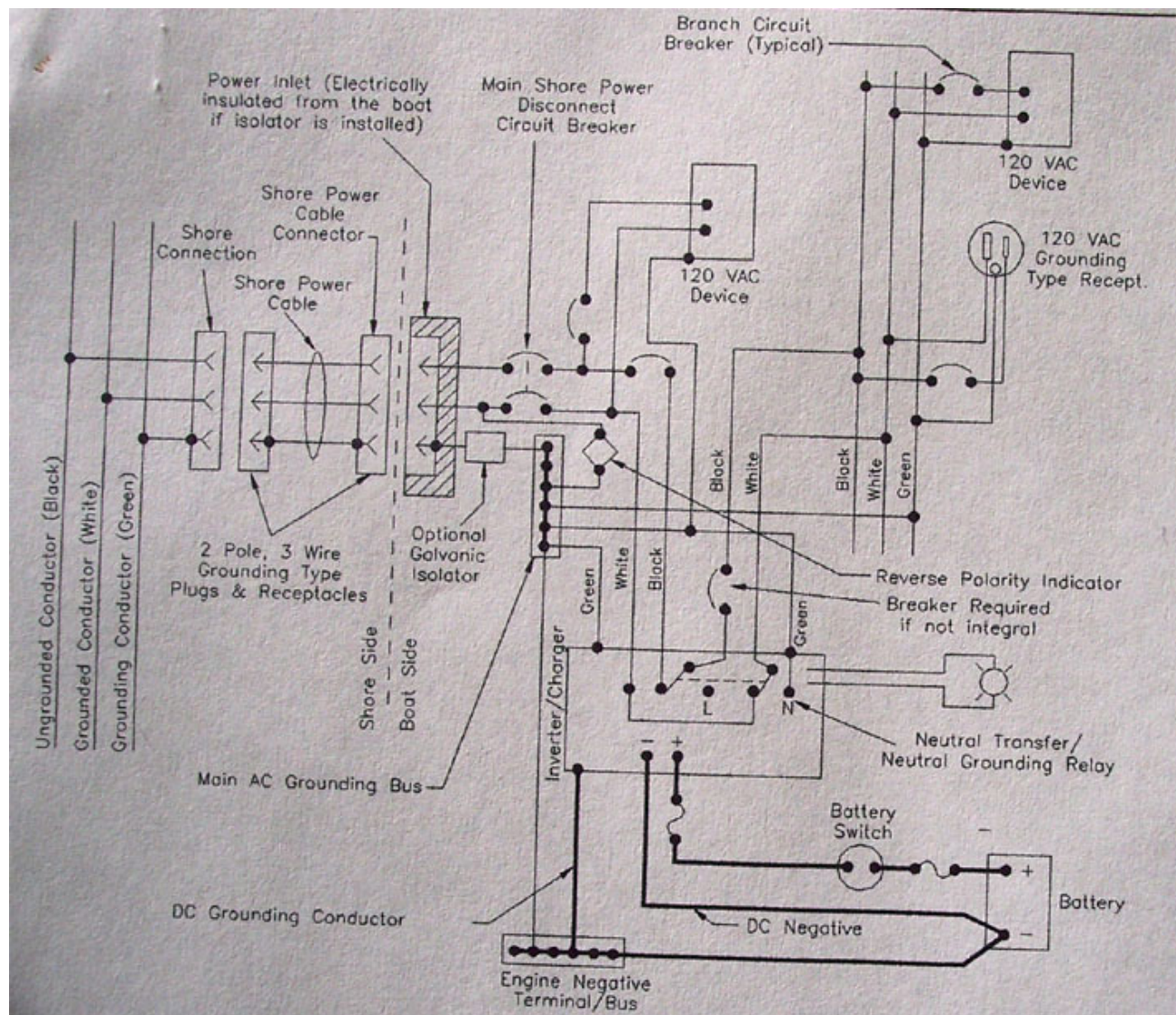

NOTE This diagram does not illustrate a complete system. Refer to the appropriate text.

Figure E.2 — Inverter/charger with internal transfer to a split bus system

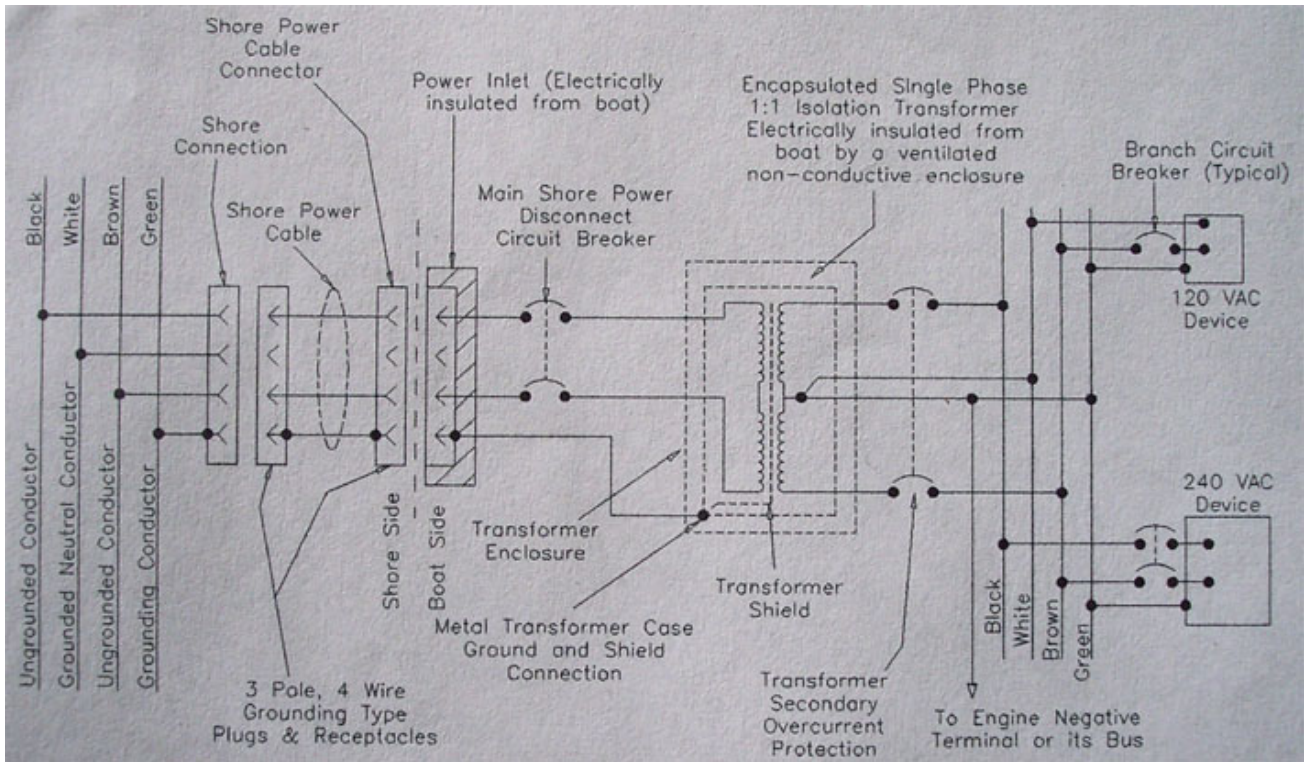

NOTE This diagram does not illustrate a complete system. Refer to the appropriate text.

**Figure E.3 — Isolation transformer system with single phase 240 Volt input, 120/240 Volt output with a boat grounded secondary, transformer shield and metal case grounded on the shore**

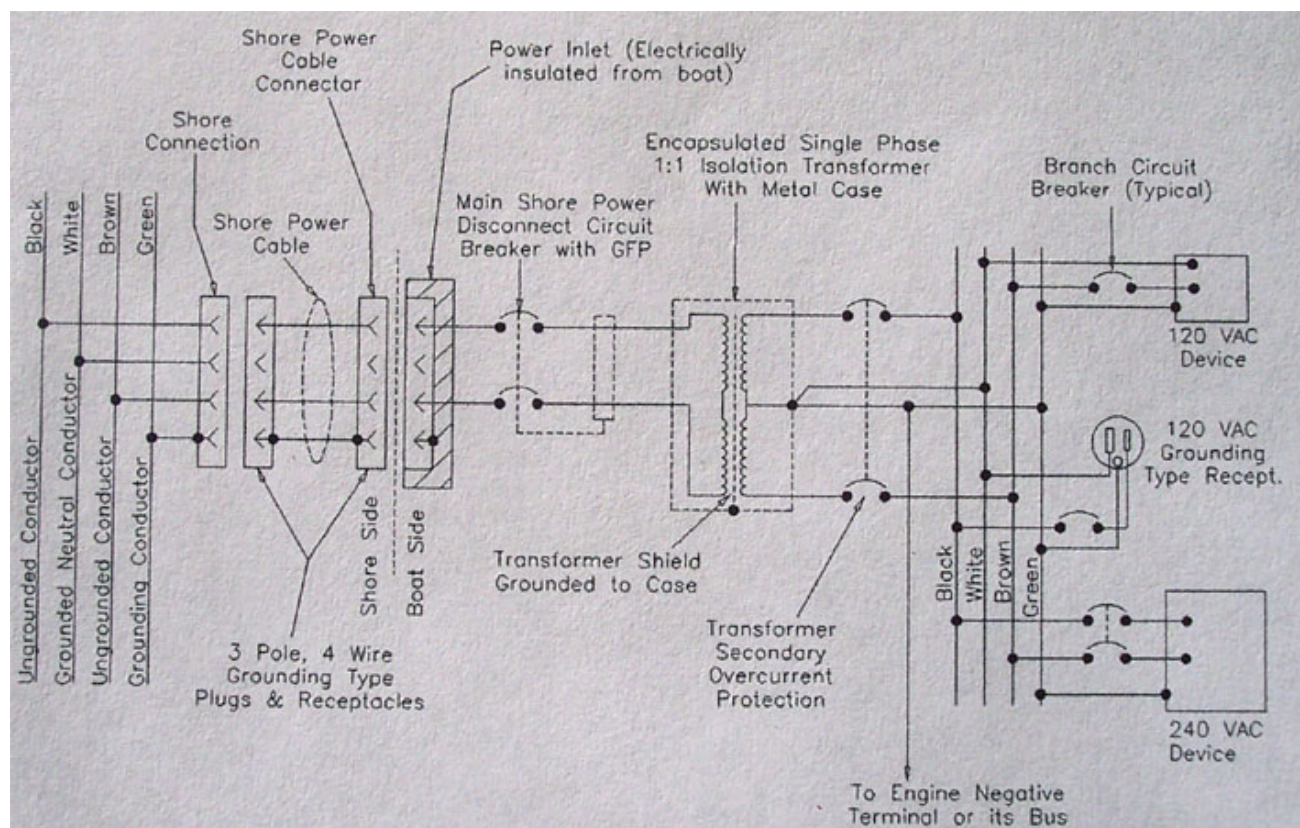

NOTE This diagram does not illustrate a complete system. Refer to the appropriate text.

**Figure E.4 — Isolation transformer system with single phase 240 Volt input, 120/240 Volt output with ground fault protection and boat grounded secondary, transformer shield and metal case grounded on the boat**

## Annex F (informative)

### Typical battery charger/inverter installation diagrams

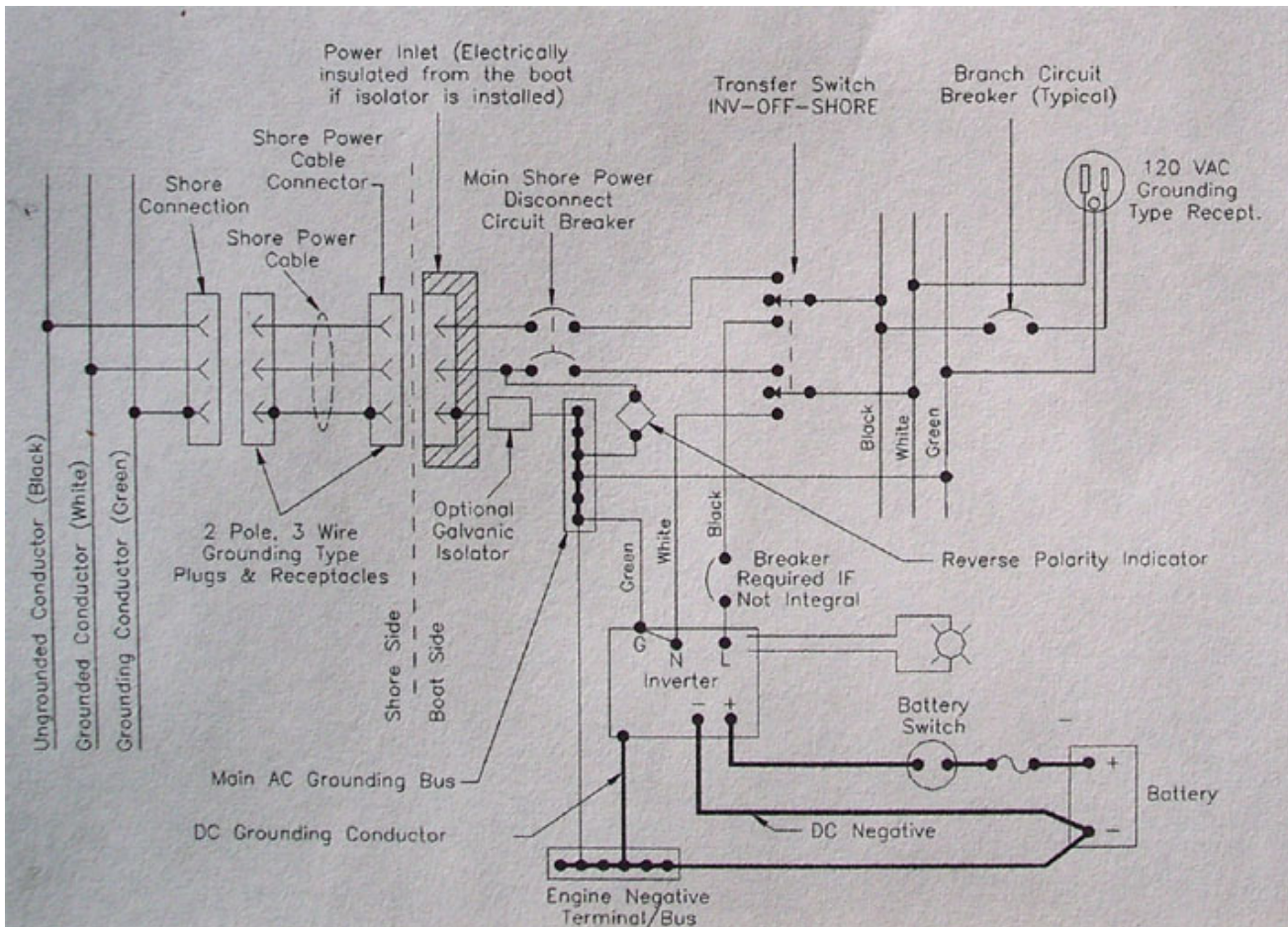

NOTE This diagram does not illustrate a complete system. Refer to the appropriate text.

Figure F.1 — Inverter with external a.c. transfer switch

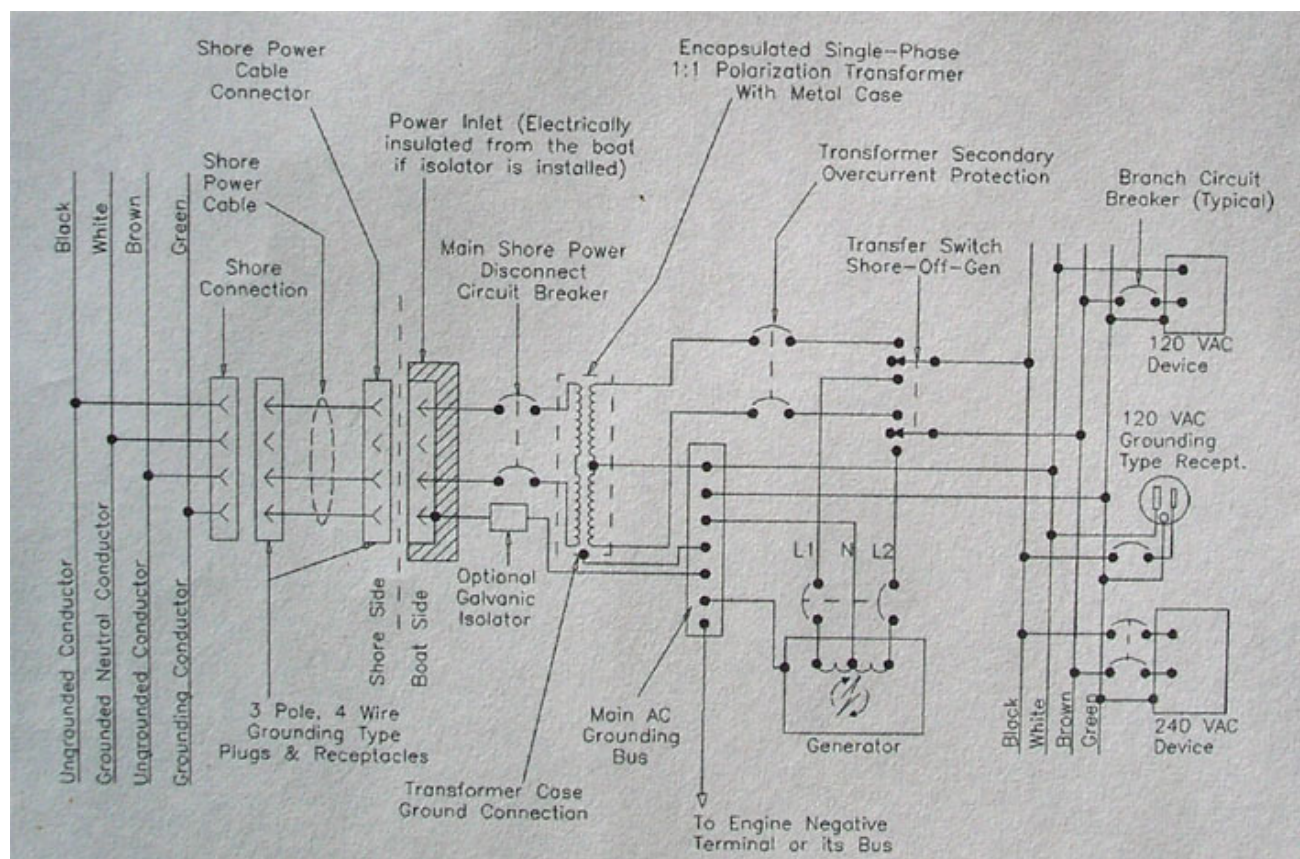

NOTE This diagram does not illustrate a complete system. Refer to the appropriate text.

**Figure F.2 — Polarization transformer system with a single phase 240 Volt input and a 120/240 Volt output and generator illustrating the use of main ac grounding bus**